

Jifei Ou¹, Lining Yao¹, Daniel Tauber², Jürgen Steimle³, Ryuma Niiyama¹, Hiroshi Ishii¹
1. MIT Media Lab, USA; 2. Royal College of Art, UK; 3. Max Planck Institute for Informatics, Germany

jamSheets

Thin Interfaces with Tunable Stiffness
Enabled by Layer Jamming





Designing Interaction by Fabricating Smart Material

“The most profound technologies are those that disappear. They weave themselves into the fabric of everyday life until they are indistinguishable from it.”

– Mark
Weiser (1999)

ENIAC
image from internet

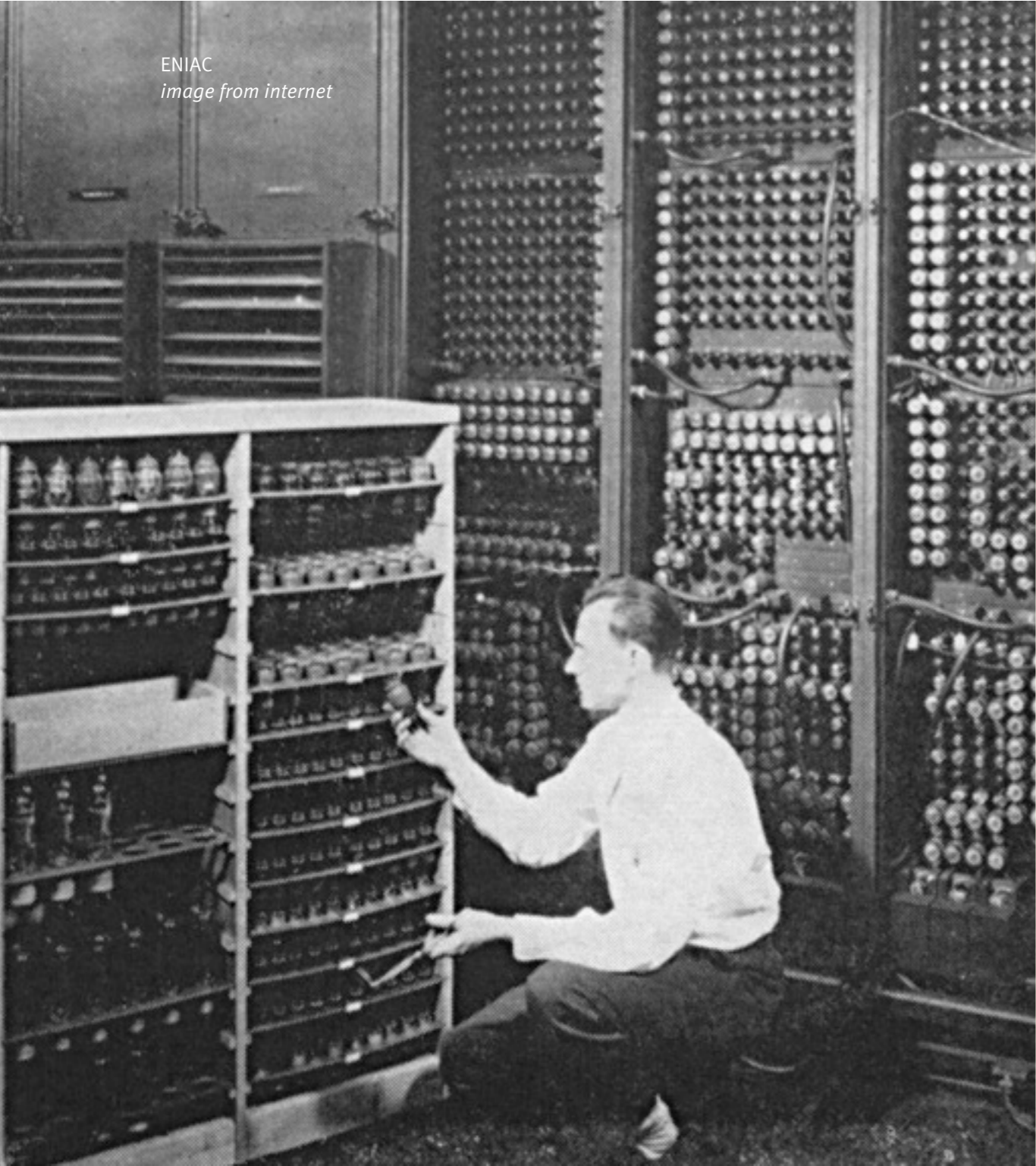

Arduino Lilypad
image from internet



images from internet

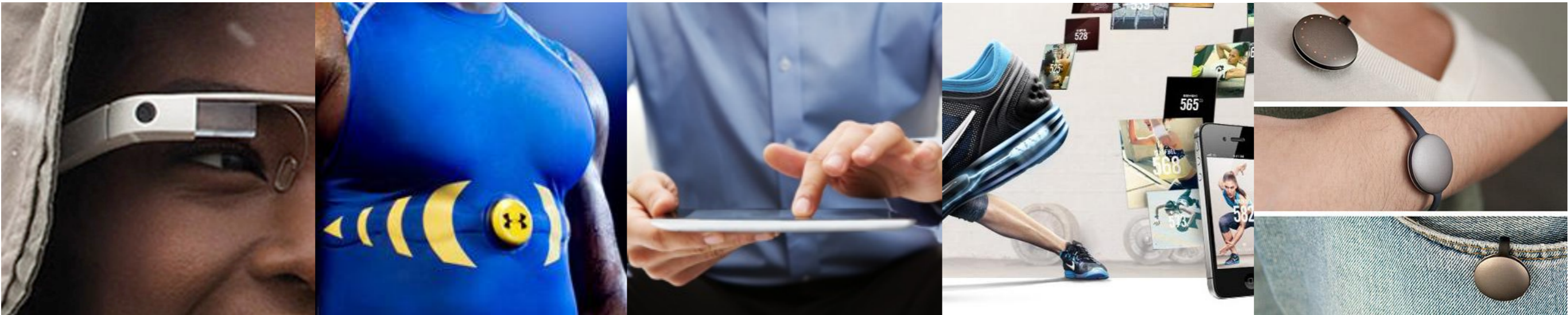

how materials carry information



how materials become information

Programmable Materials

Soft Clay
images from internet

Stiffness



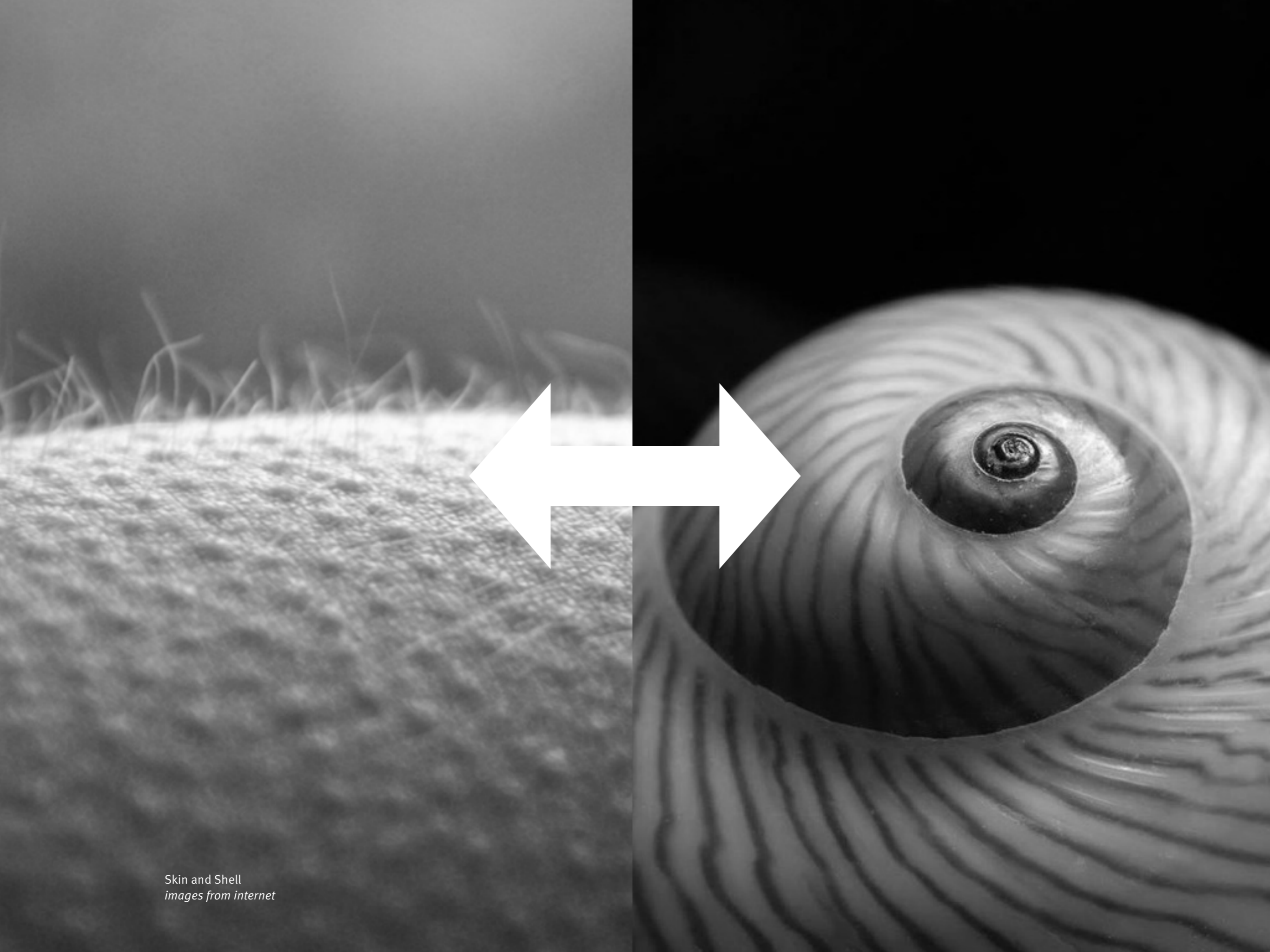

Skin and Shell
images from internet

Variable Stiffness Techniques in HCI

Magnetorheological (MR) Fluid

MudPad
[Jansen et al. 2010]



Motor Control

SqueezeBlock
[Gupta et al. 2010]

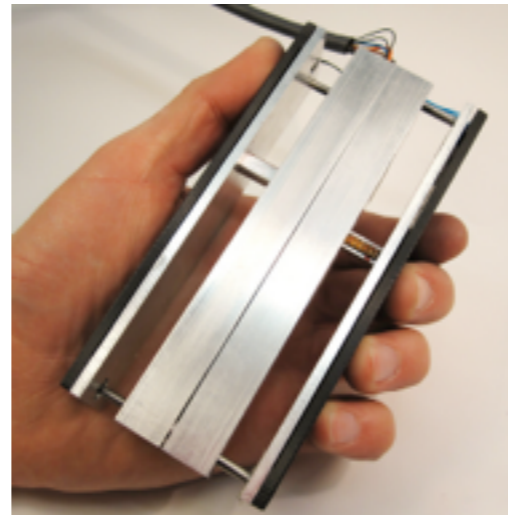

Particle Jamming

Jamming UI
[Follmer et al. 2012]

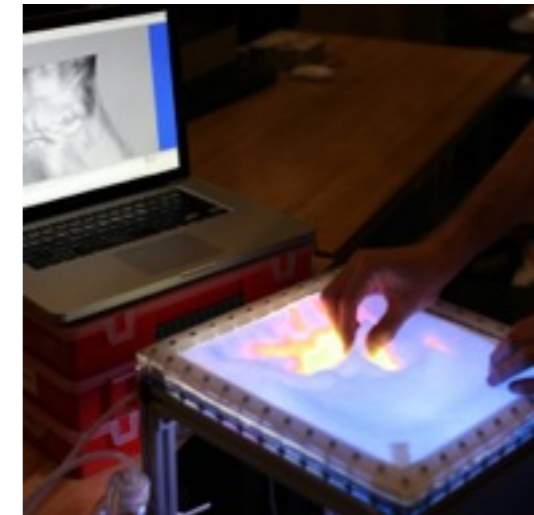

Jamming Techniques in Robotics

Universal Gripper
[Brown et al. 2010]



Jamming Skin Enabled Locomotion
[Steltz et. al. 2009]



Layer Jamming Manipulator
[Kim et al. 2013]

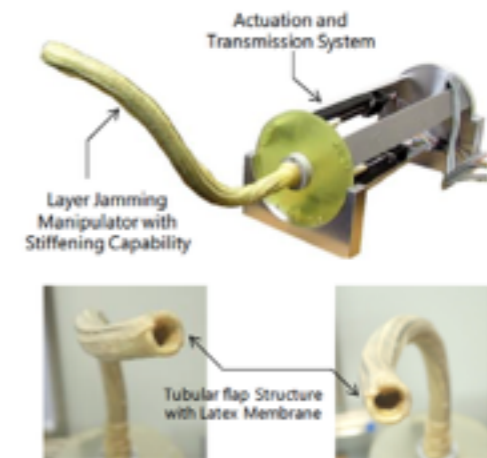



Pneumatic Control System

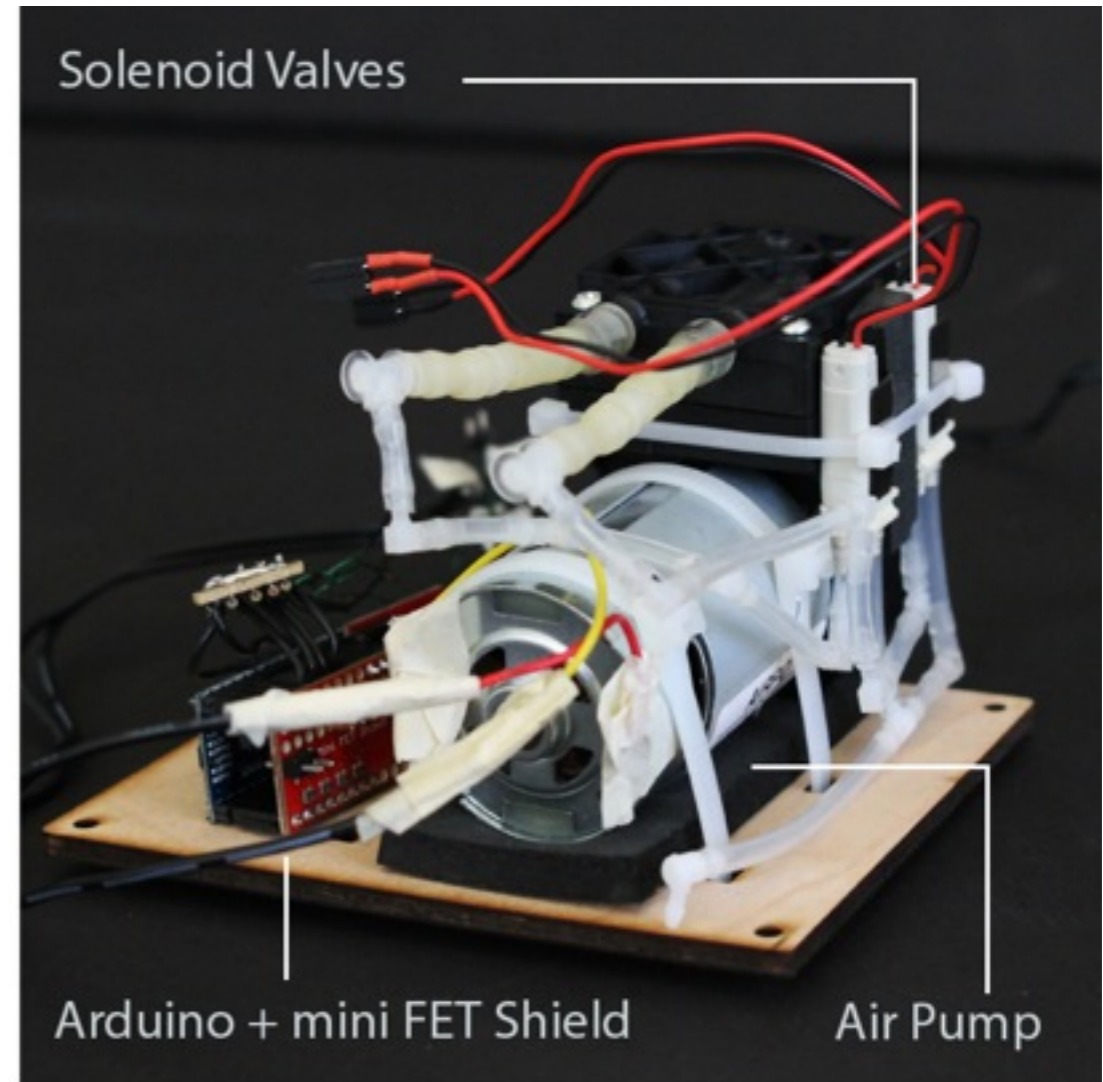
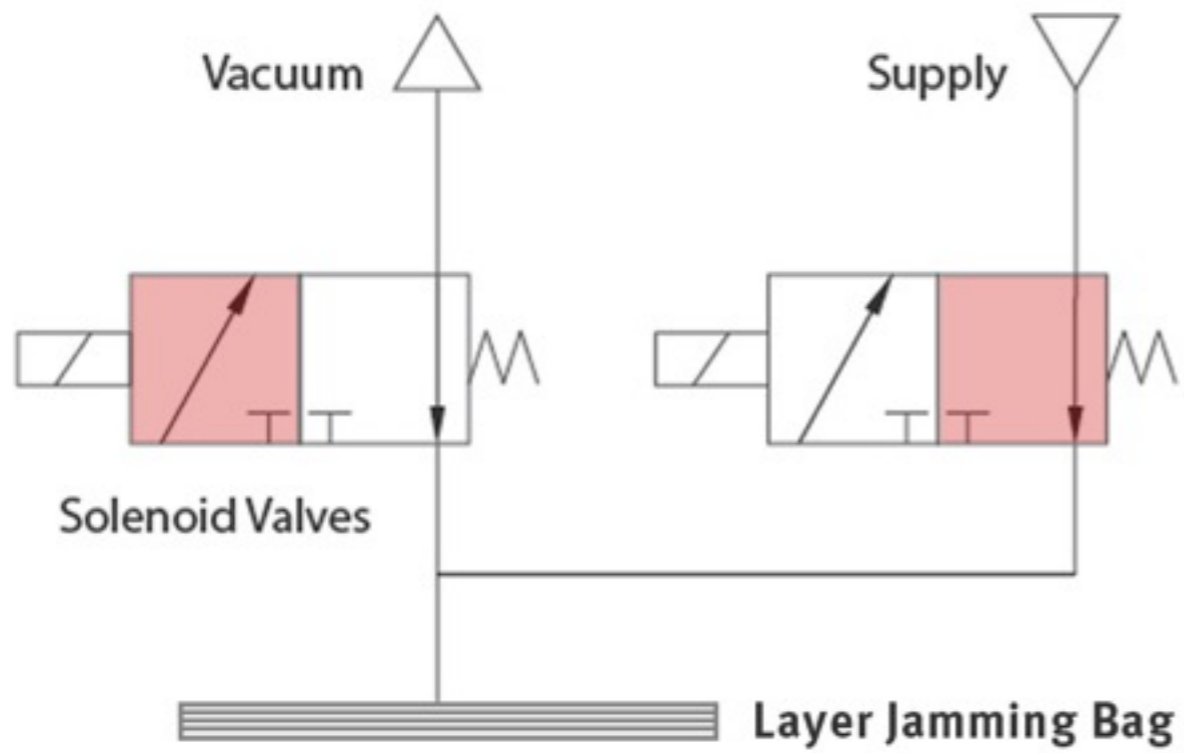

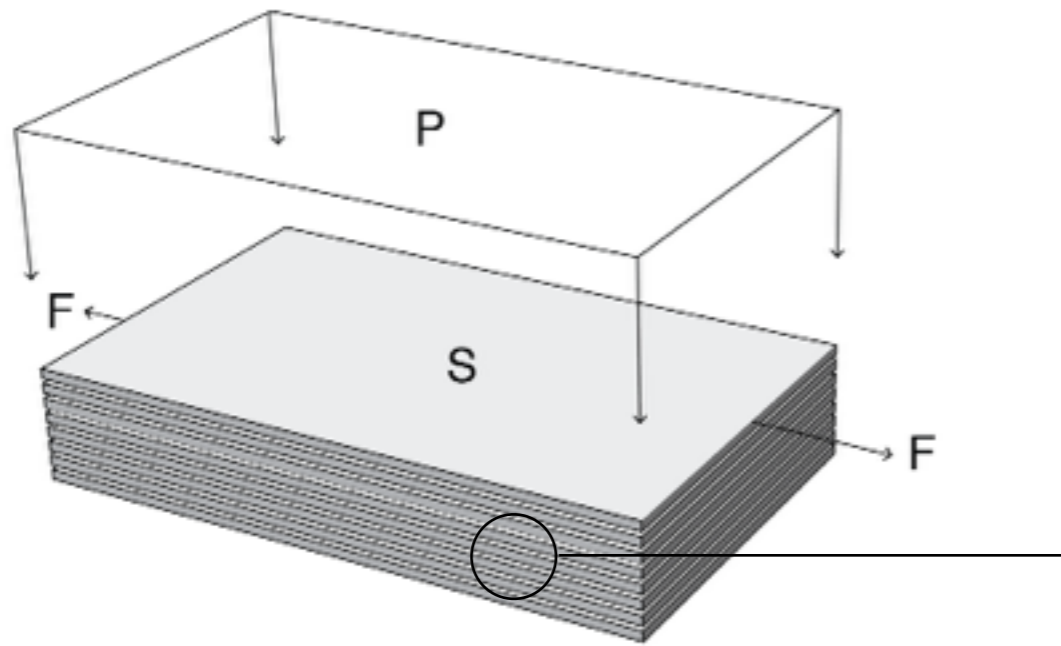

without pressure

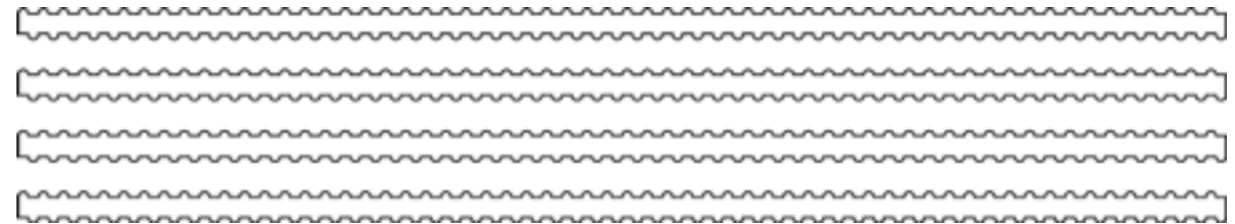

the maximum resisting tensile force:

$$F = \mu n P S.$$

S: overlapped surface area ,

P: negative air pressure ,

n: number of the layers present;

μ: friction coefficient.

under pressure

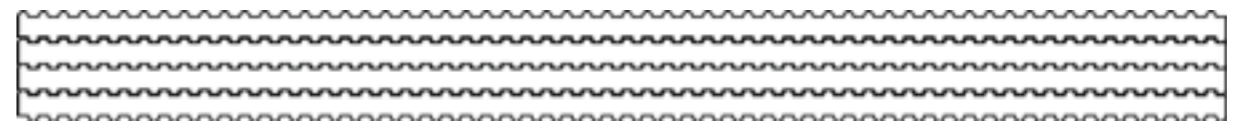

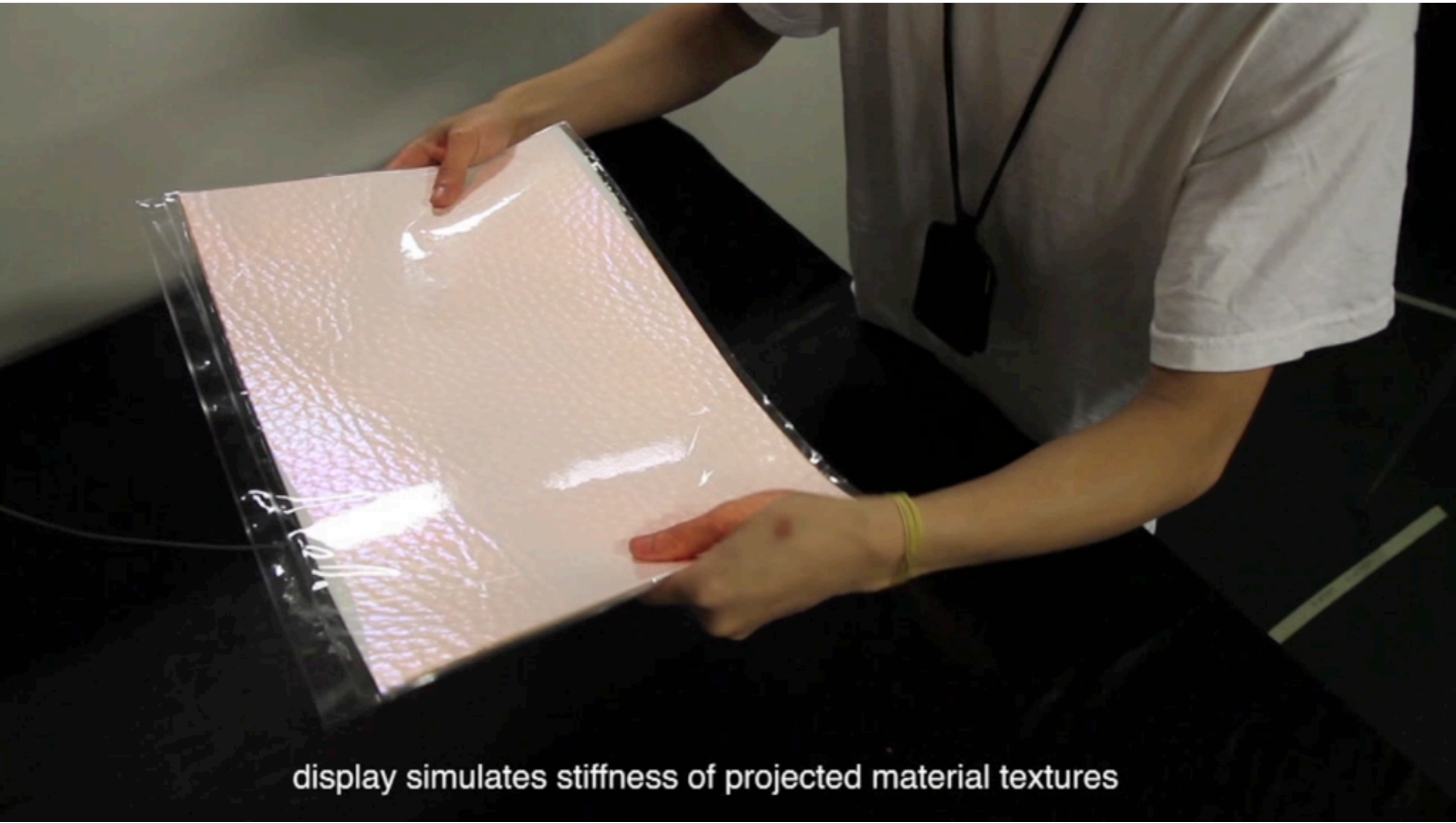

display simulates stiffness of projected material textures

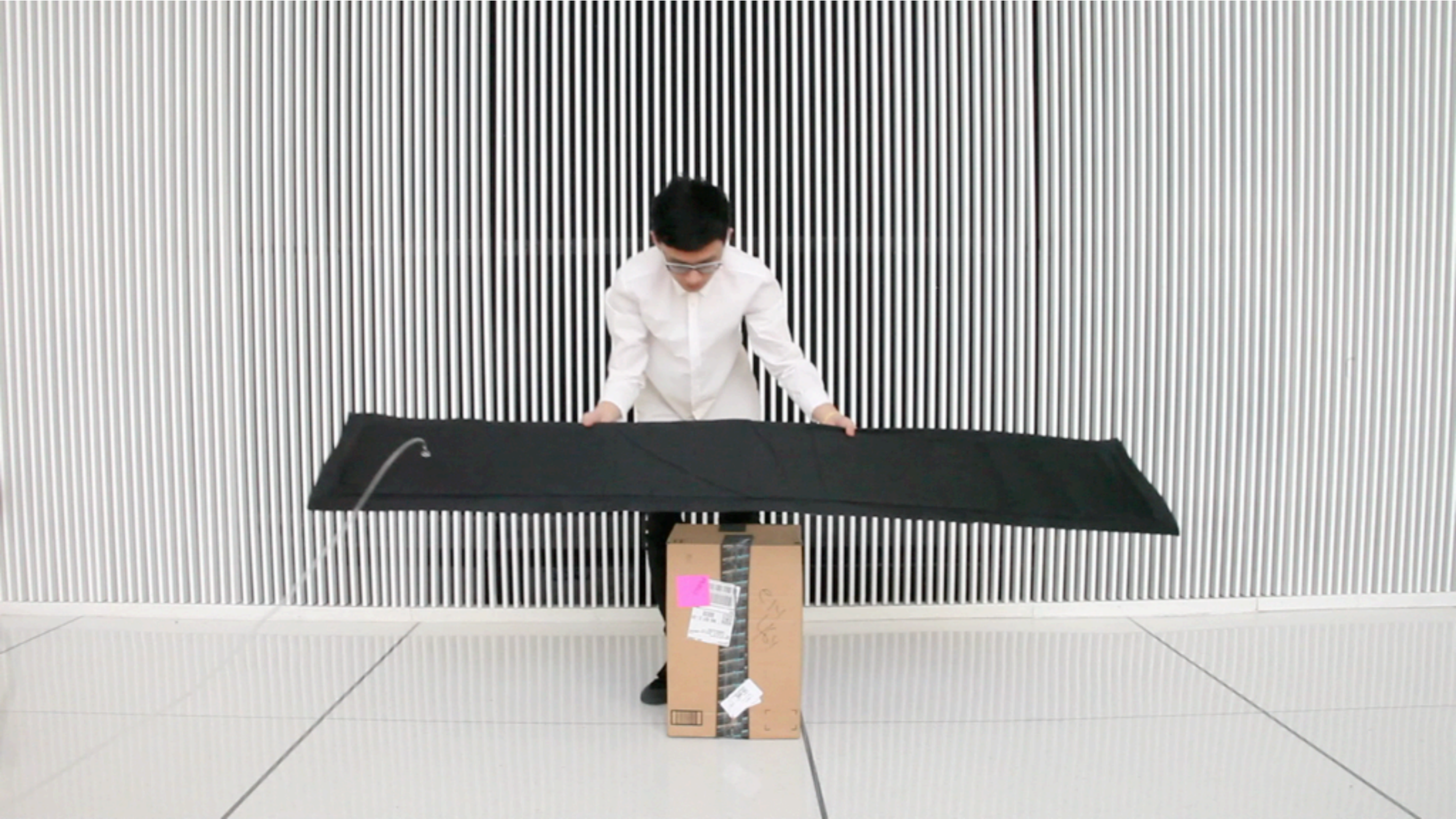

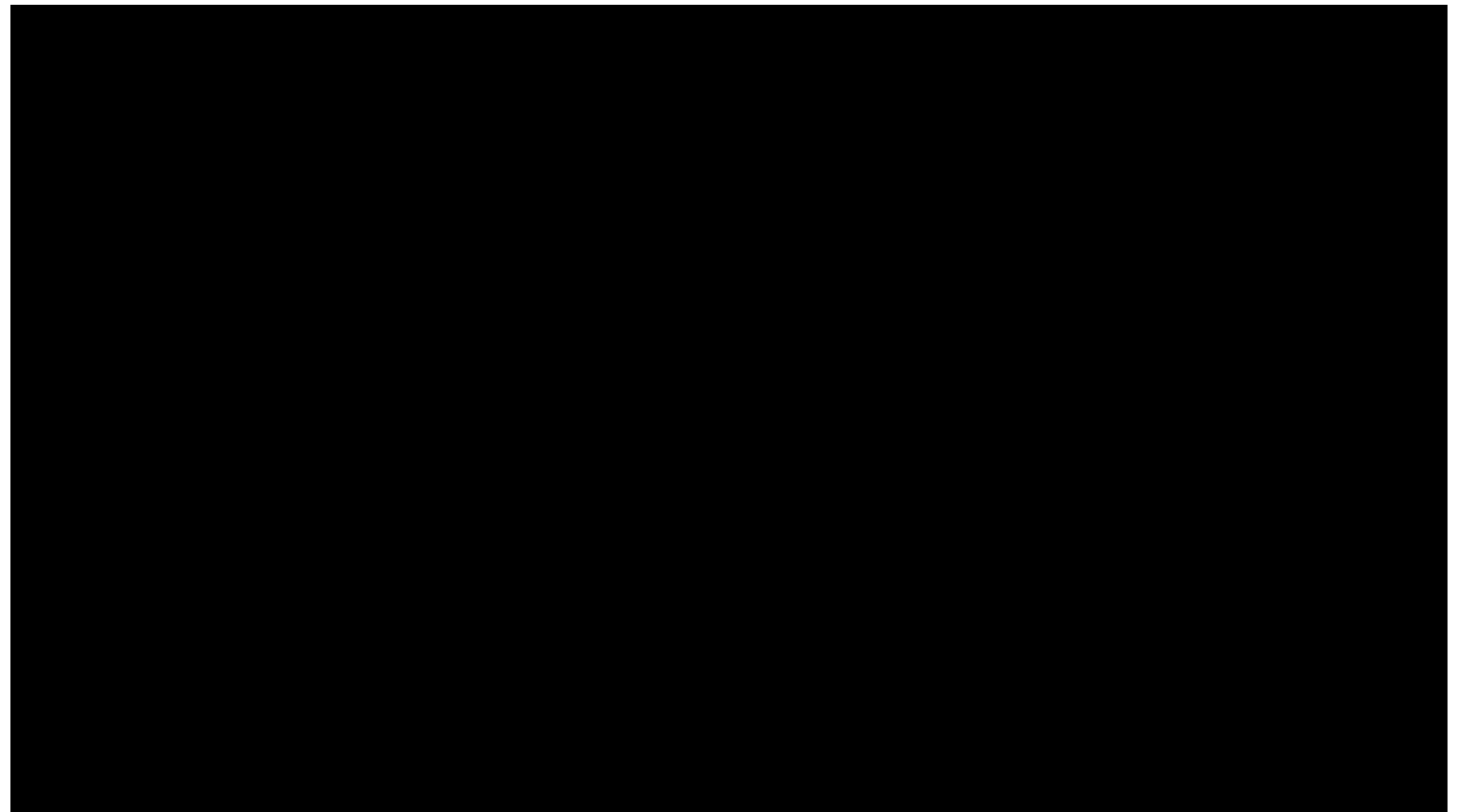
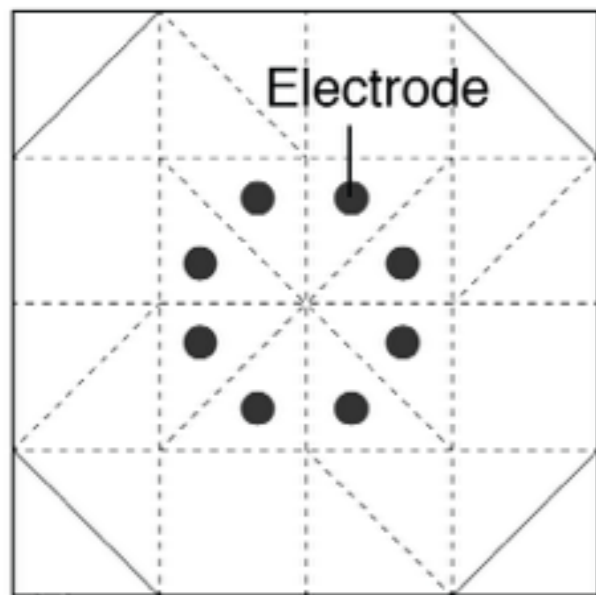

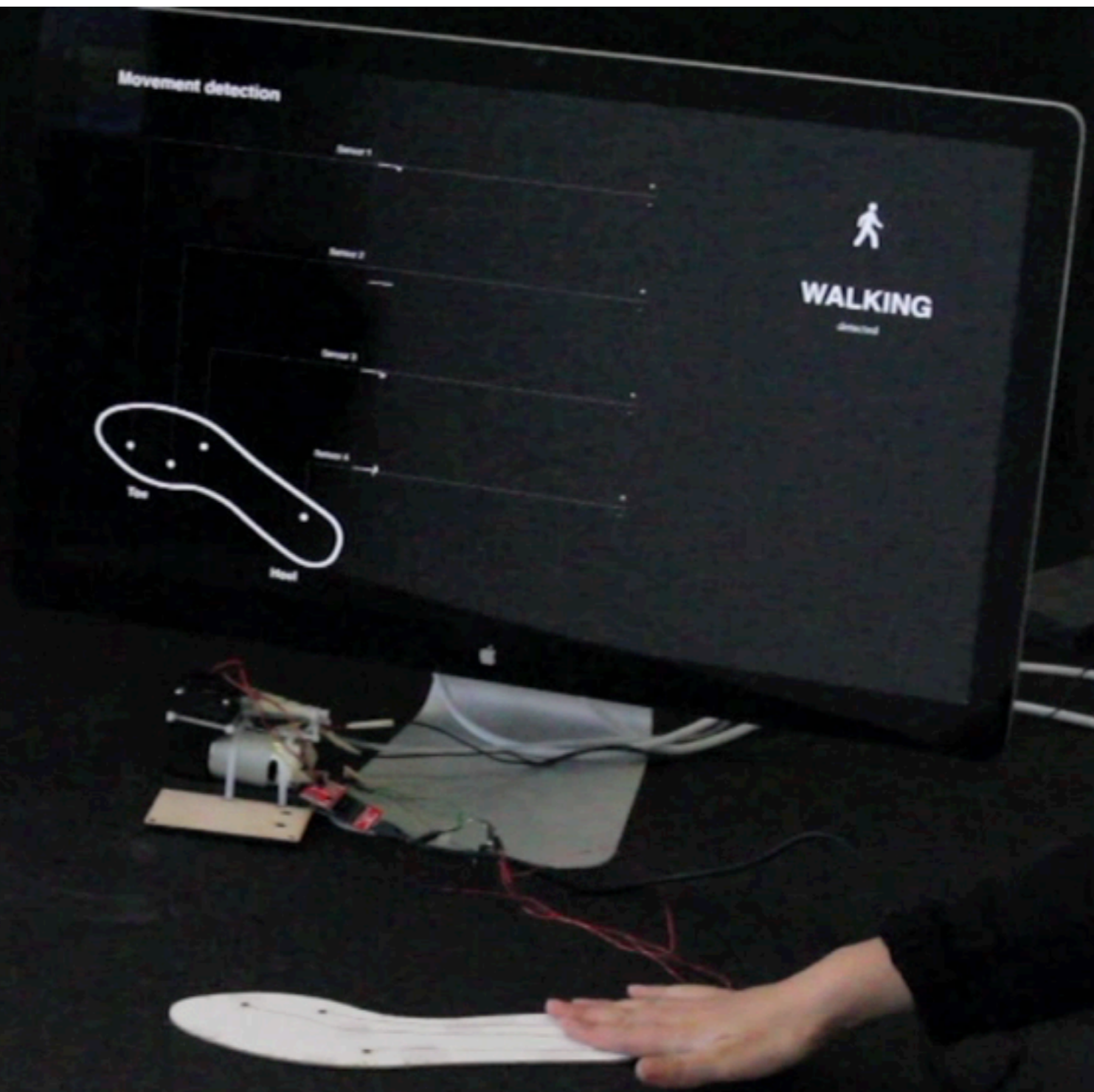



MS94D
8-0122

new balance

NB



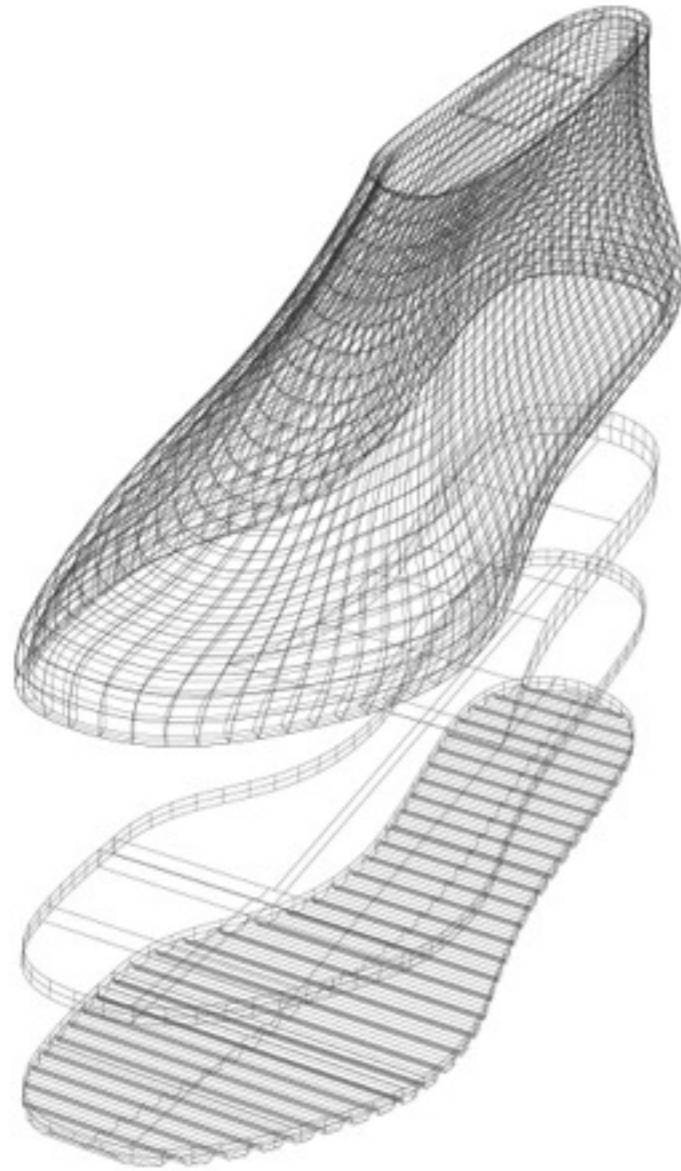

Integrate manual pump inside the sole

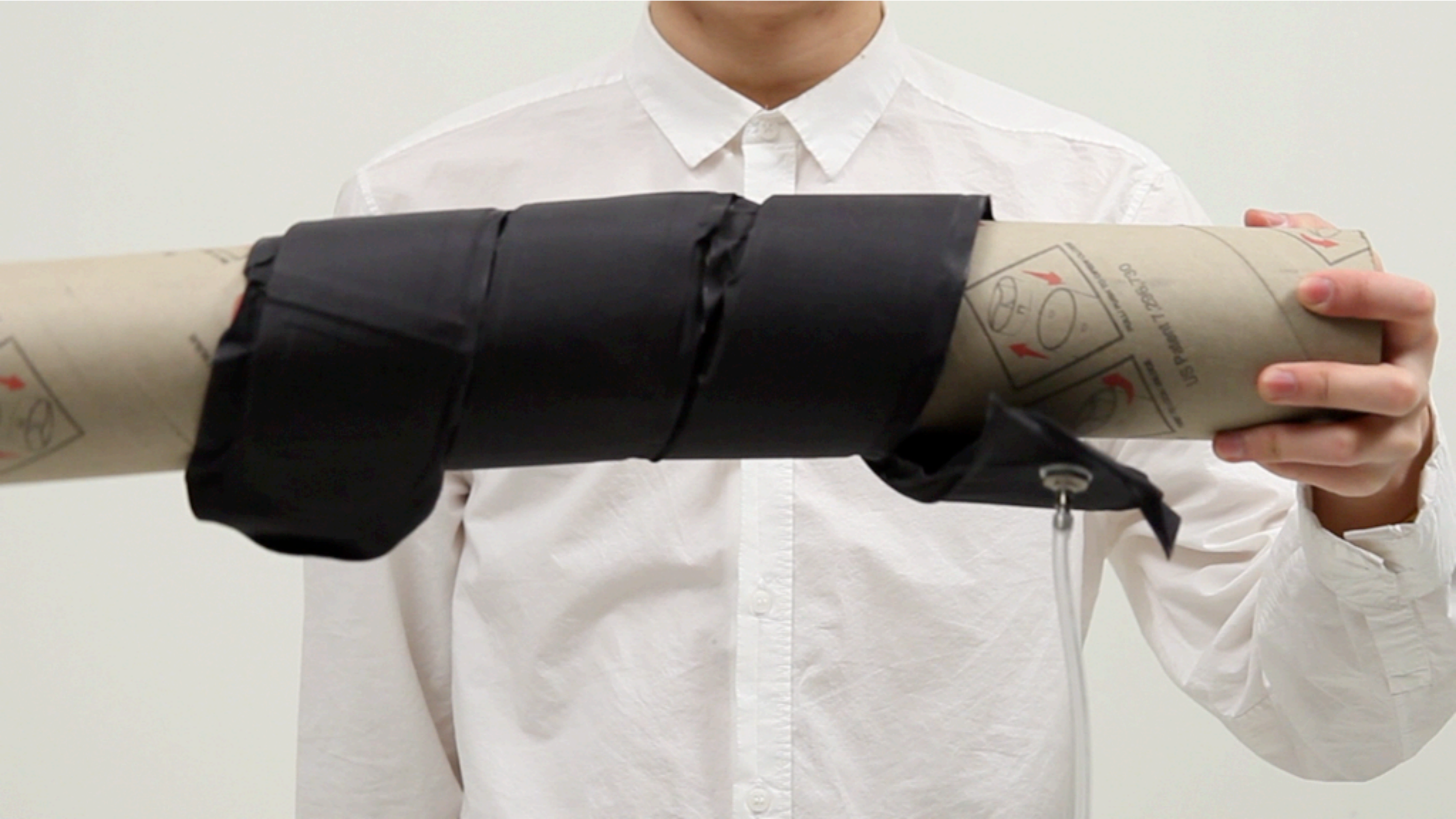

Encoding Stiffness-changing Information in the Material

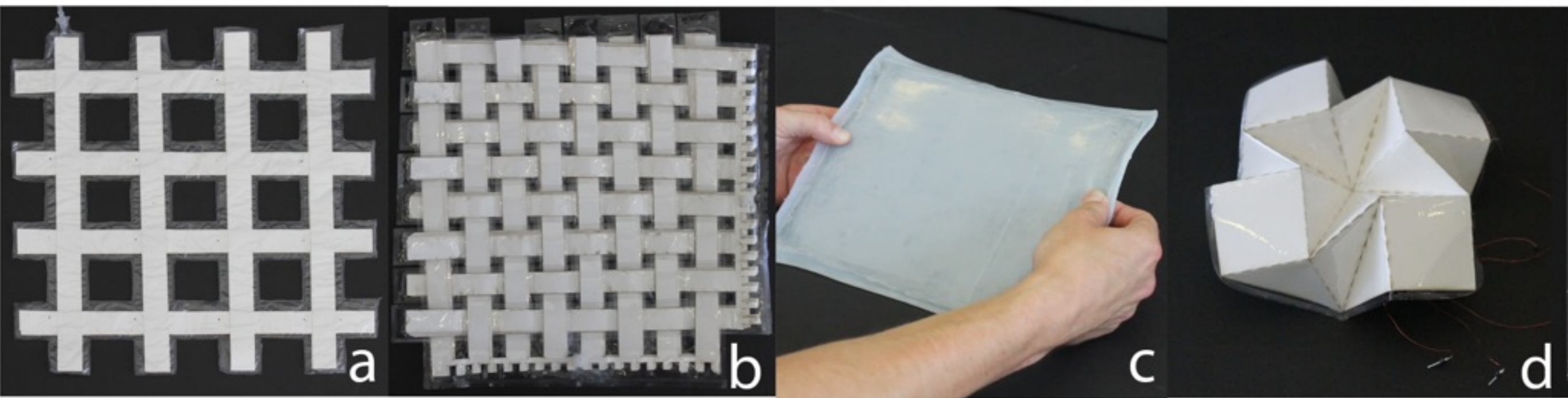

A. Jamming Mesh

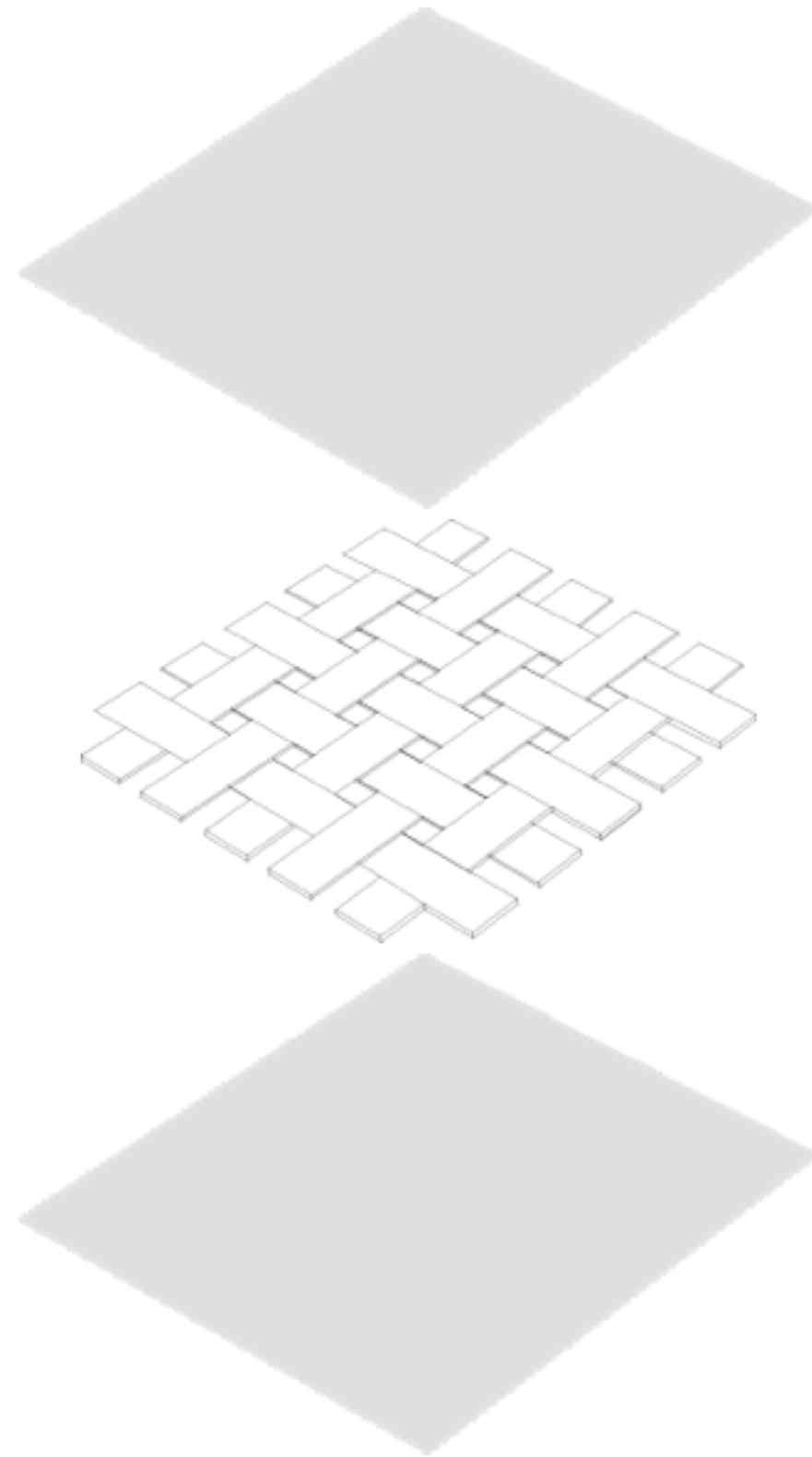
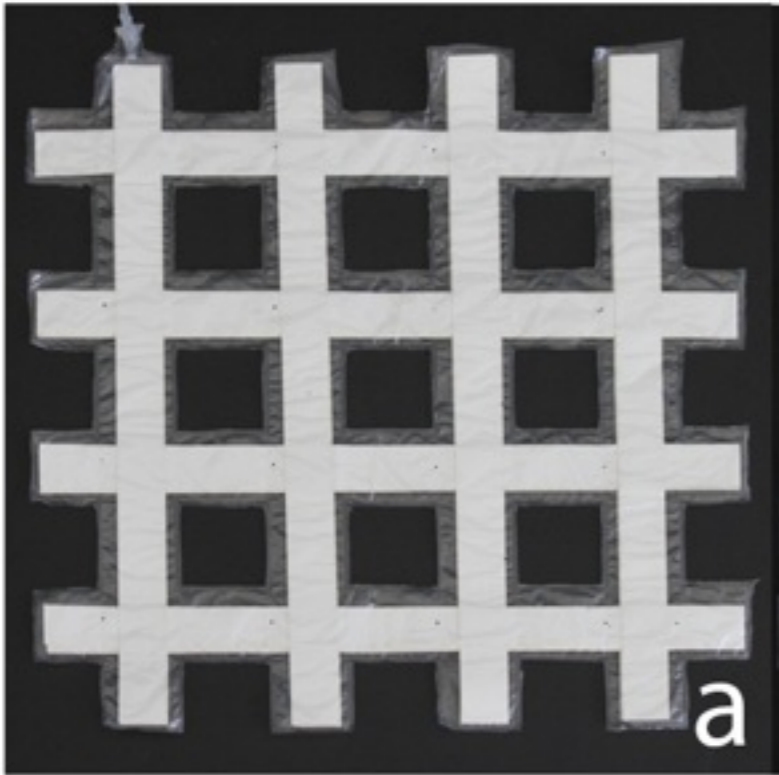

A. Jamming Mesh

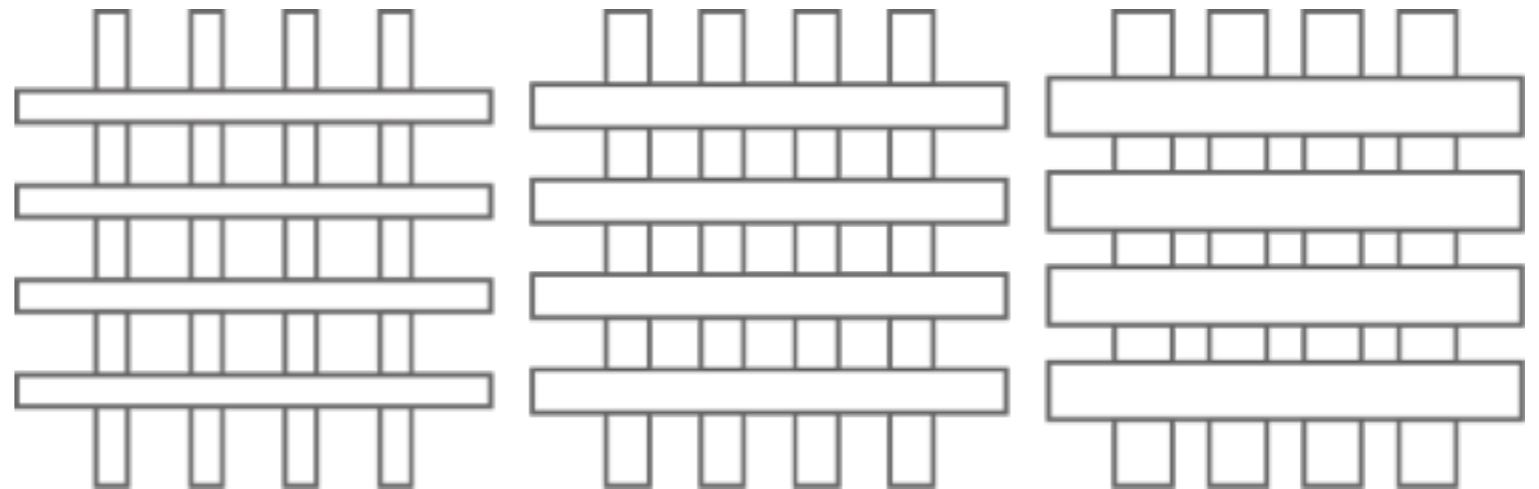
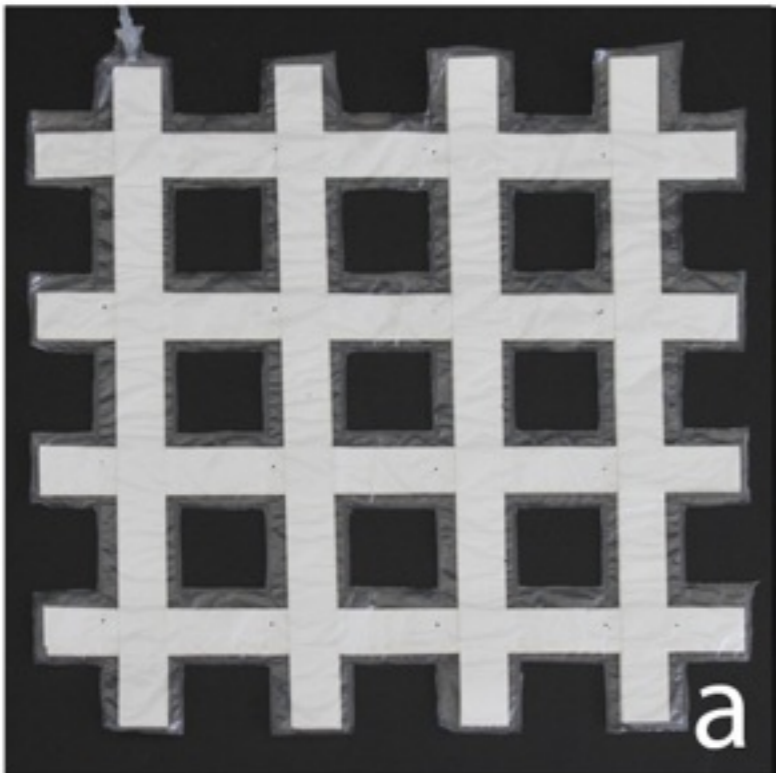

B. Addressable Stiffness

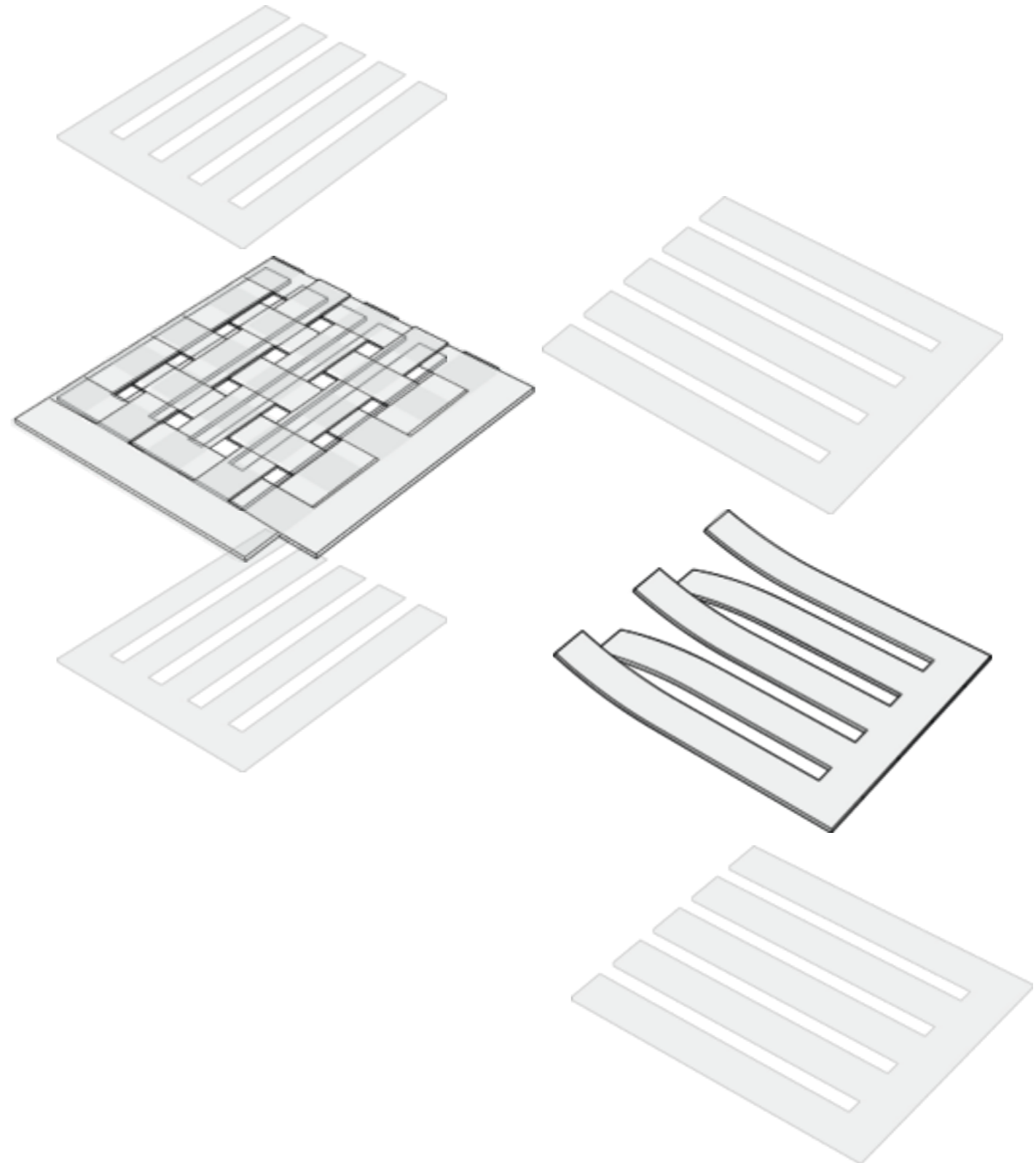
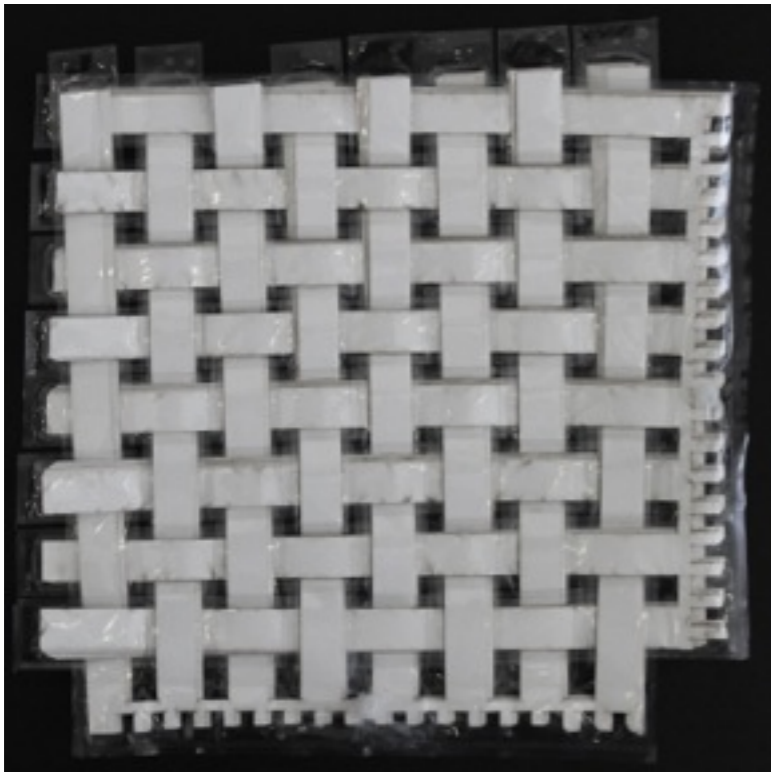

B. Addressable Stiffness

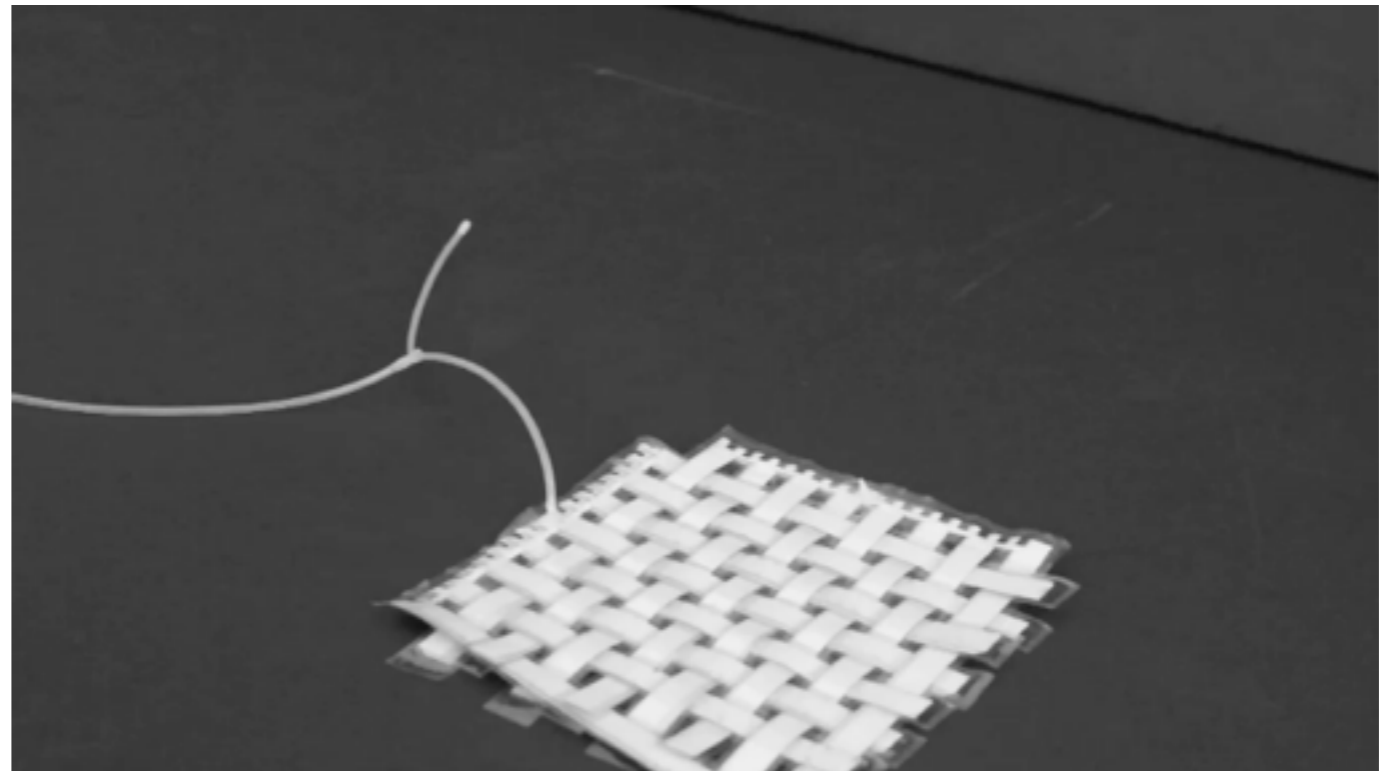
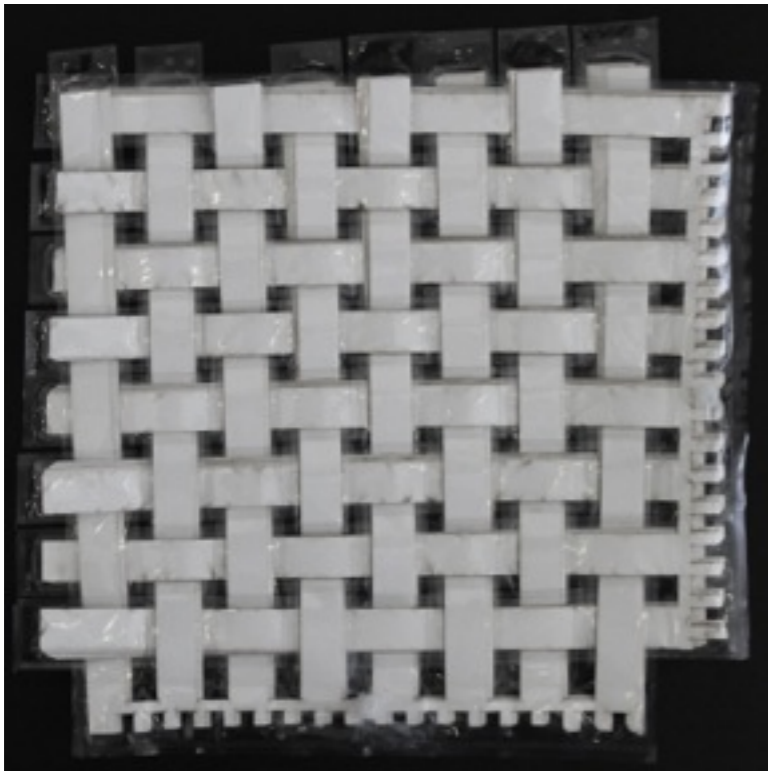

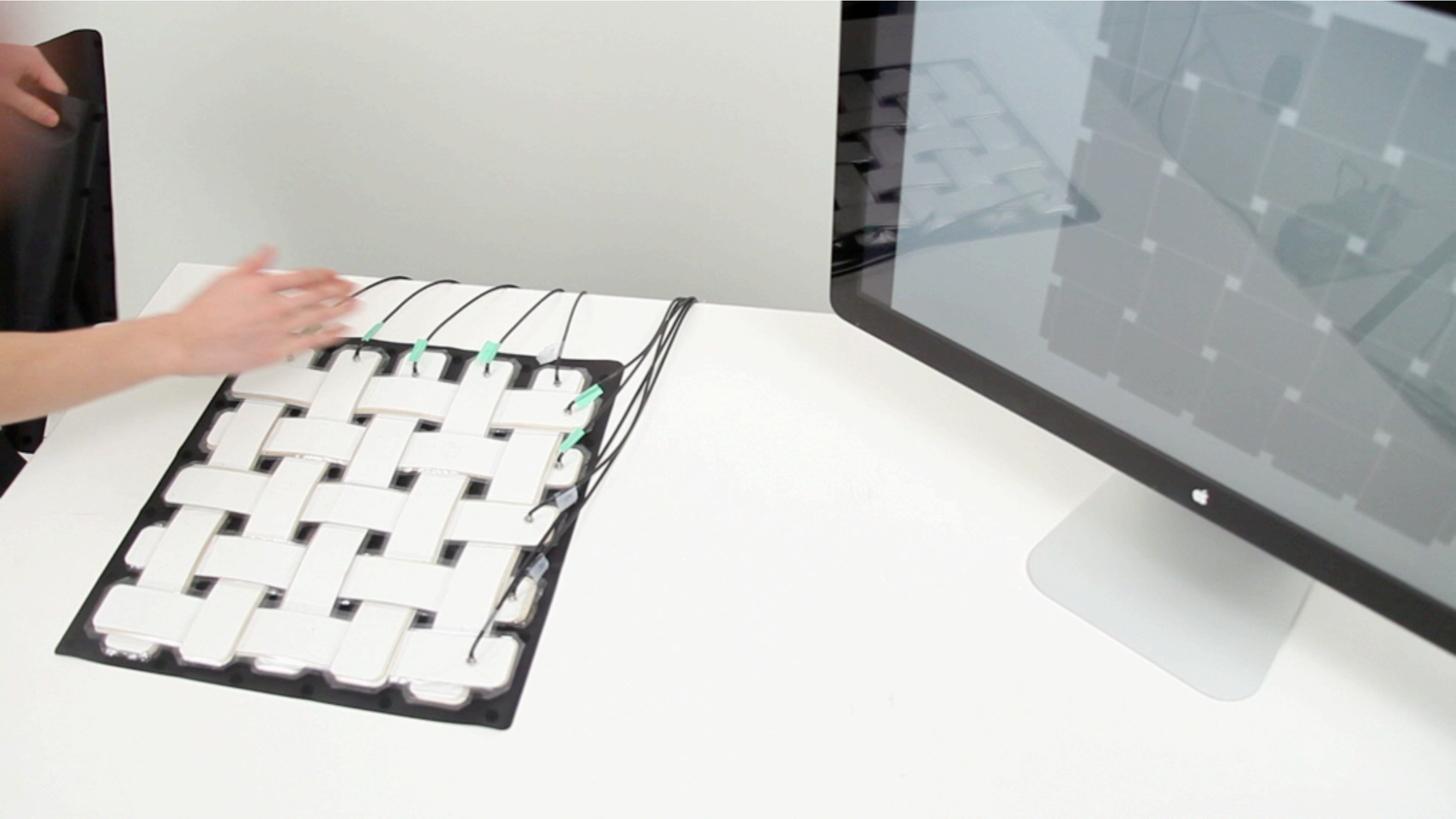

jamSheets
2013

arm cast

stretch

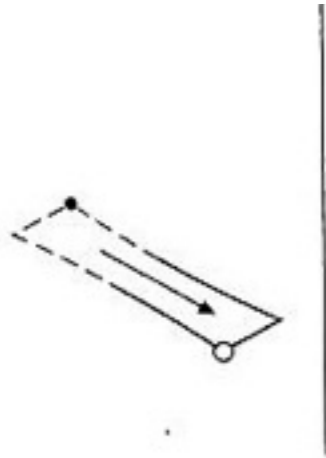

roll

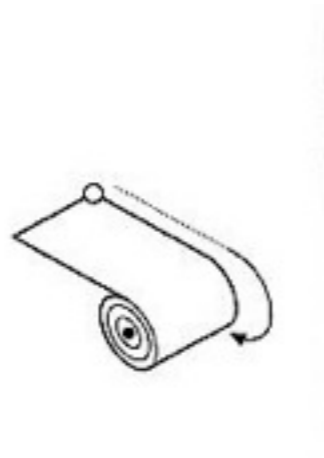

bend

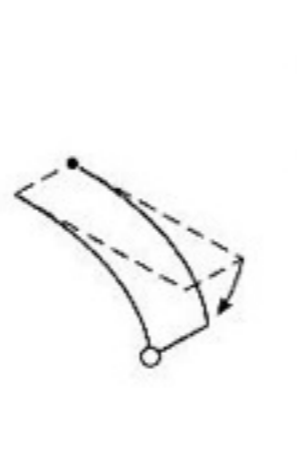

shear

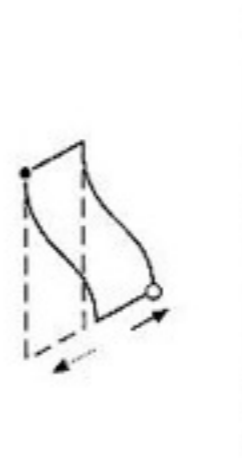

flutter

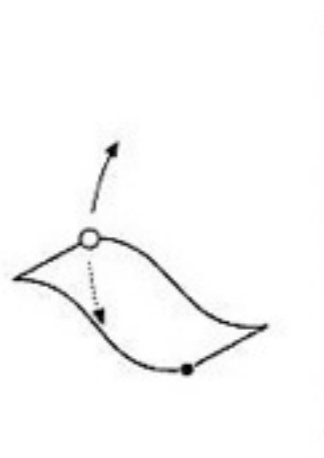

free

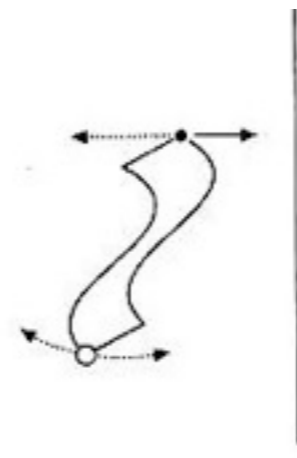

gather (vertical)



gather (horizontal)

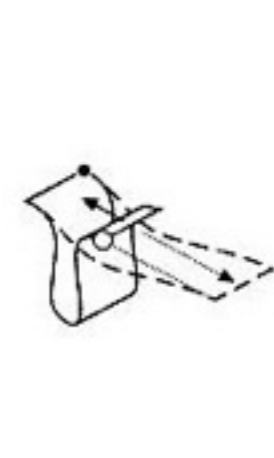

C. Jamming with Volume Change

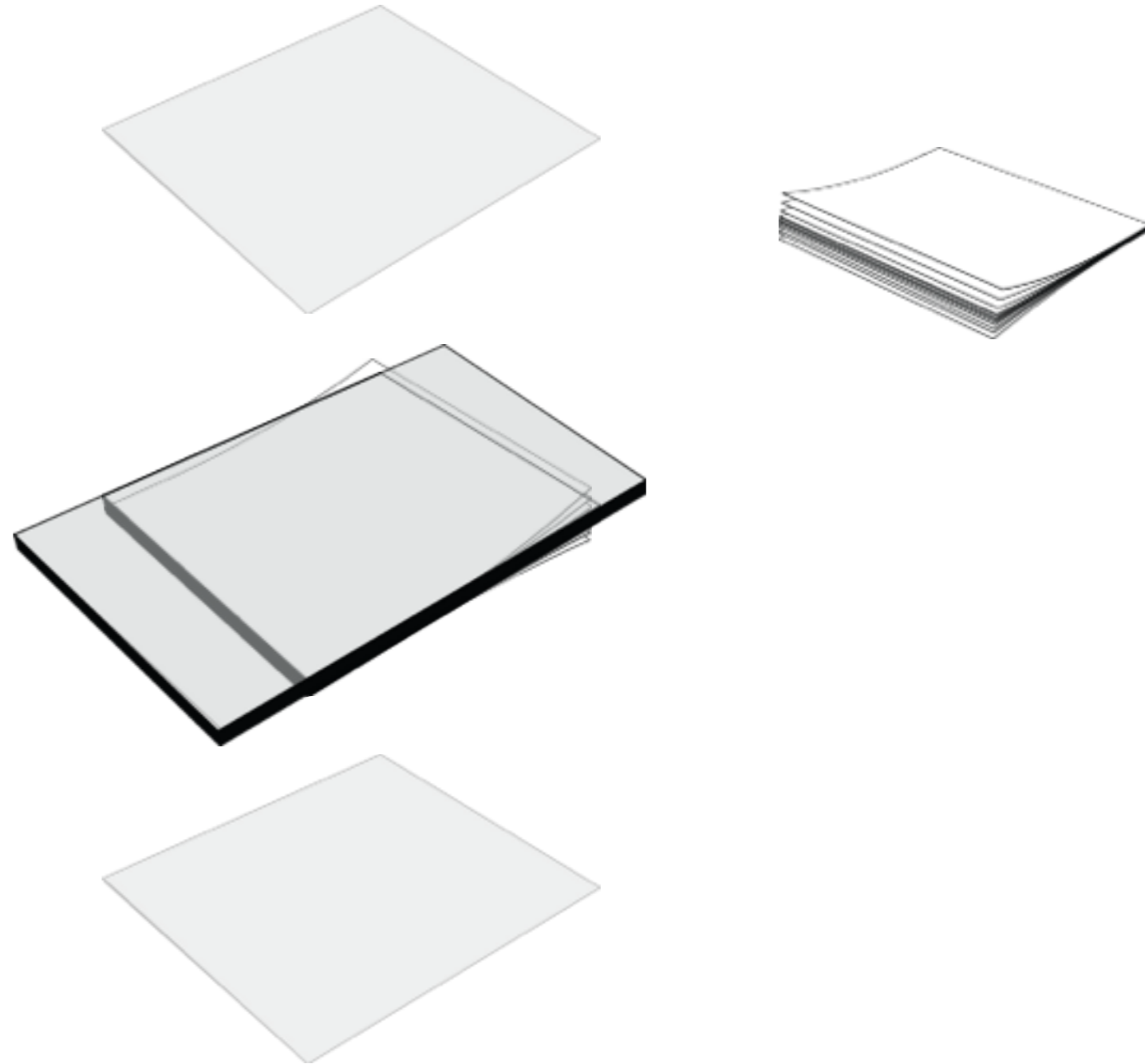
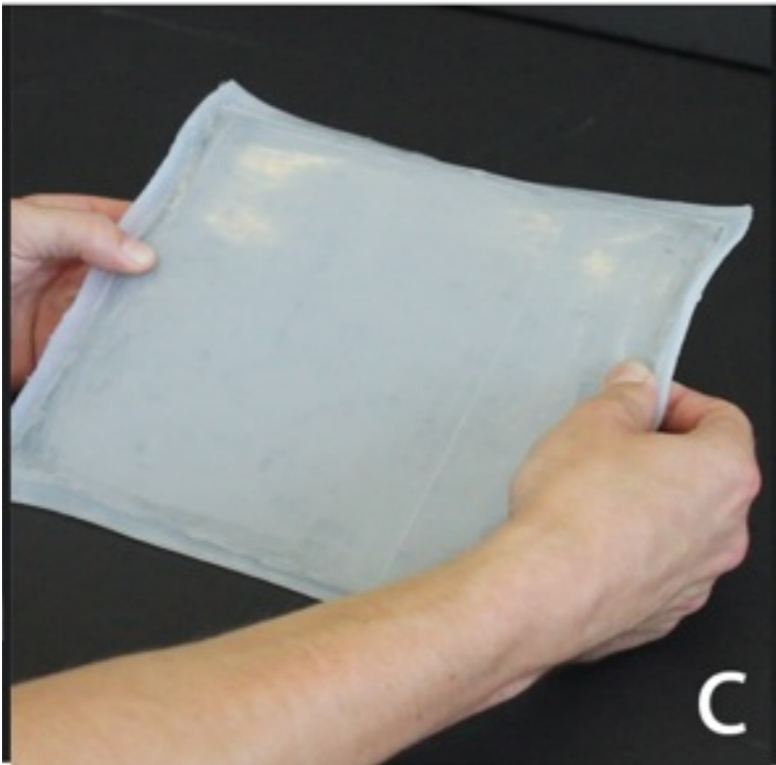

D. Stiffness-changing Origami

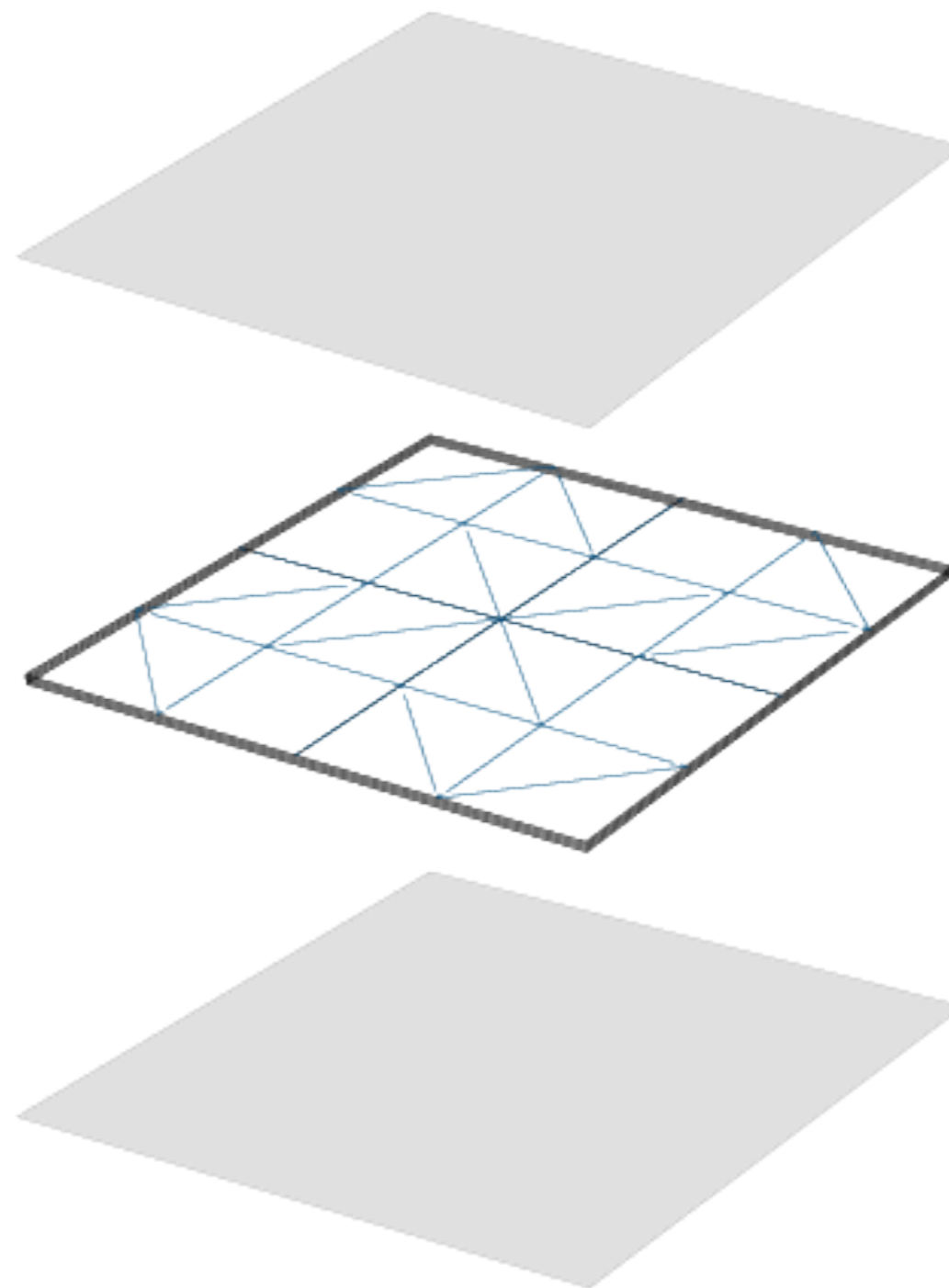
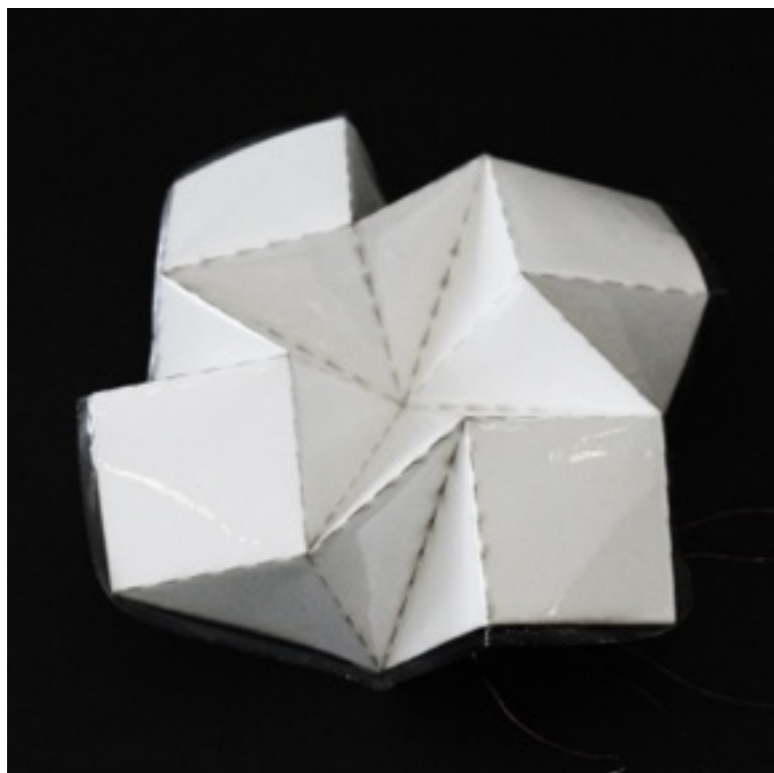

D. Stiffness-changing Origami

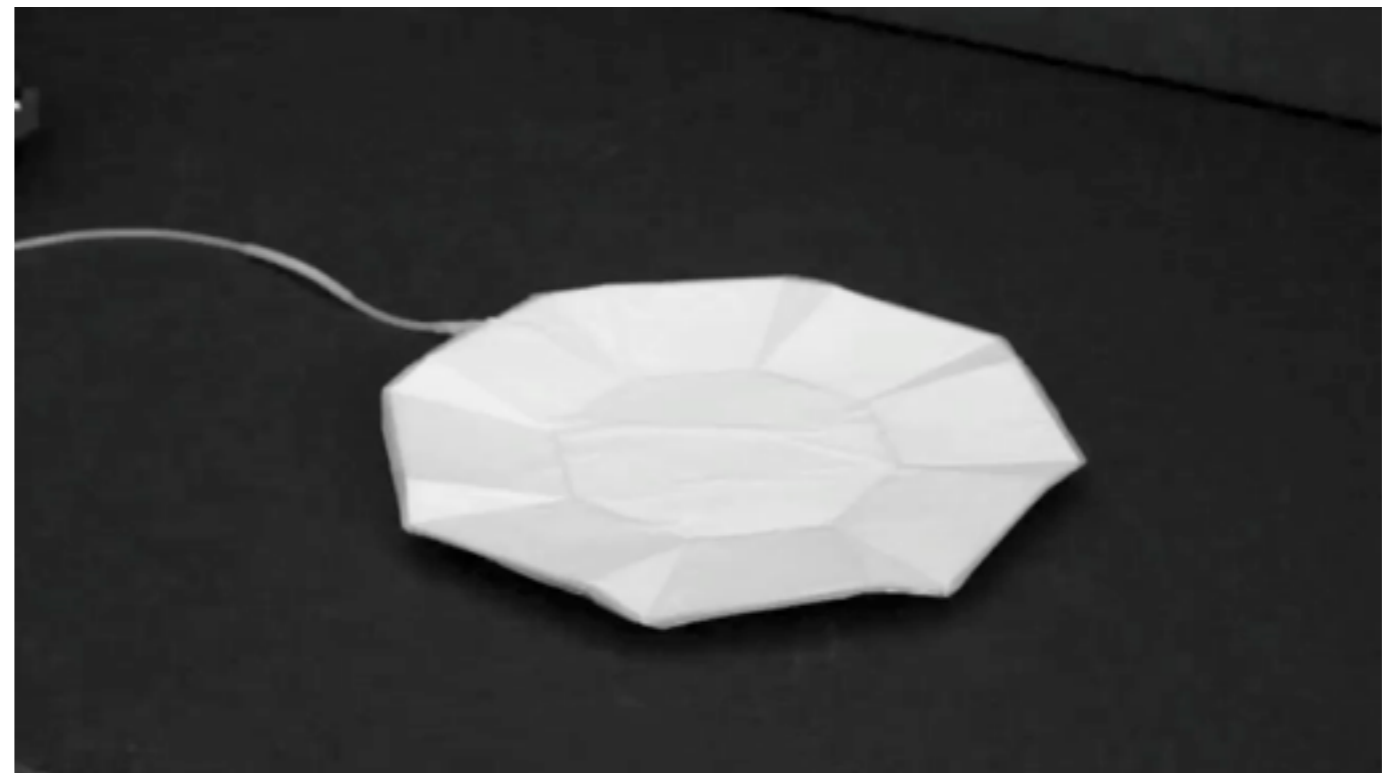
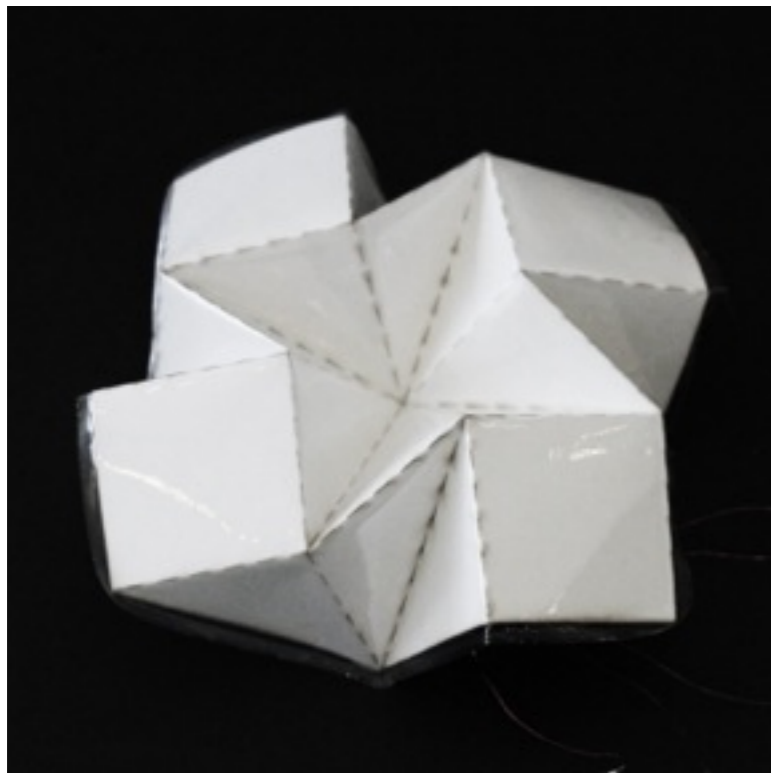



4 ingredients to cook stiffness-changing interfaces

Sheet Shaped
Material

Composite Sensing
Layer

Structural
Design

Pneumatic
Control

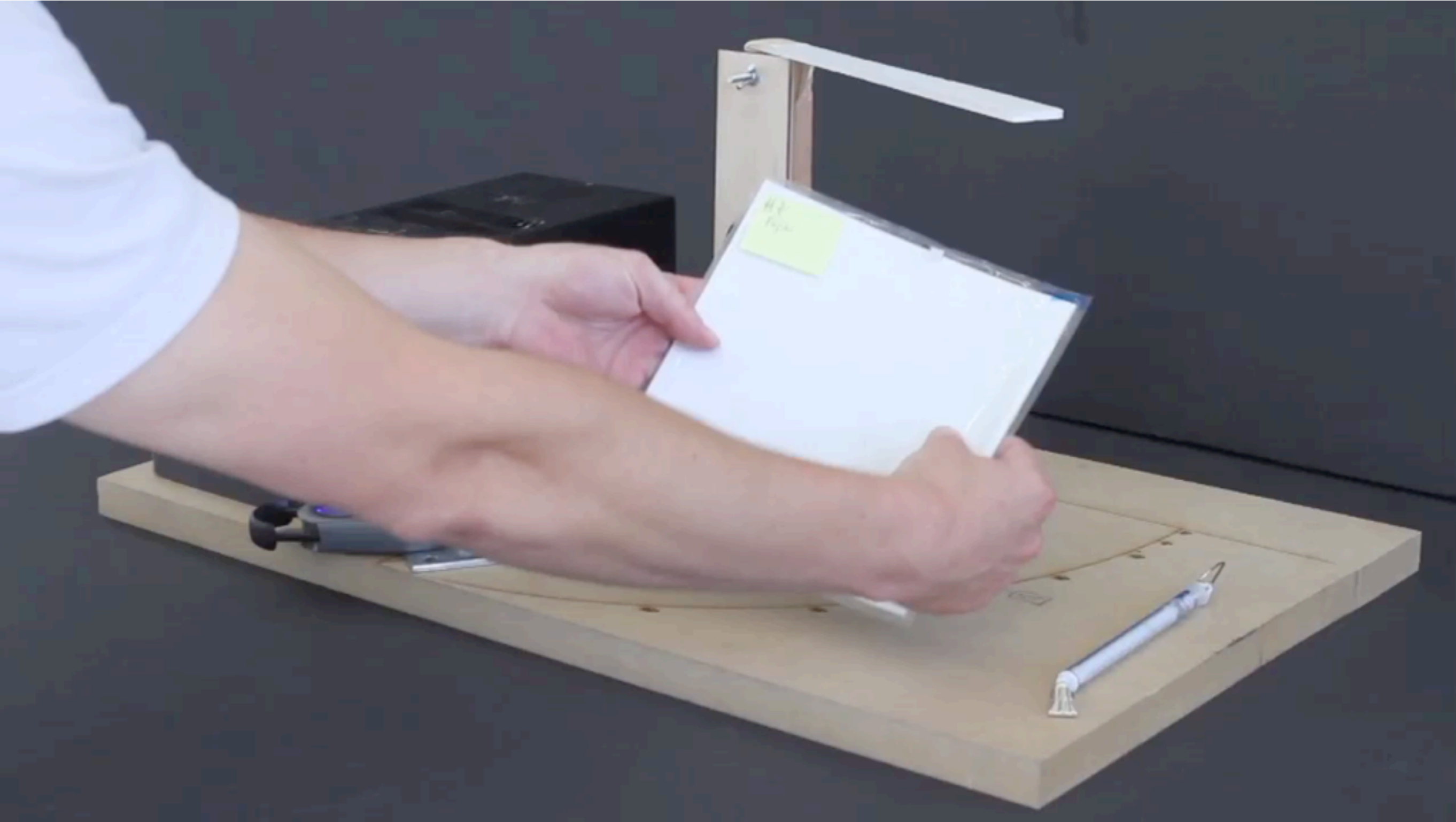

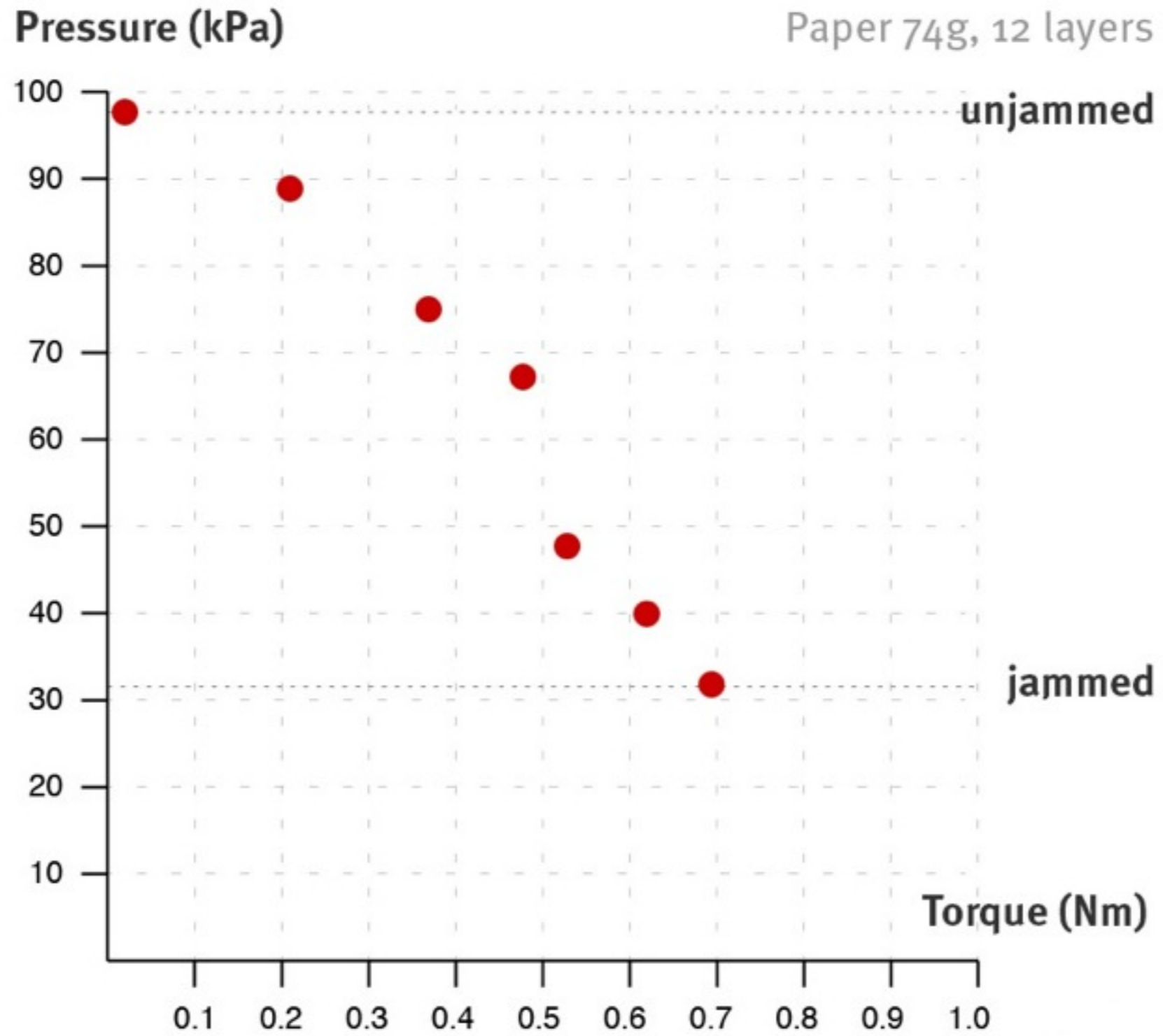

JAMMING MATERIALS SELECTION AND TEST

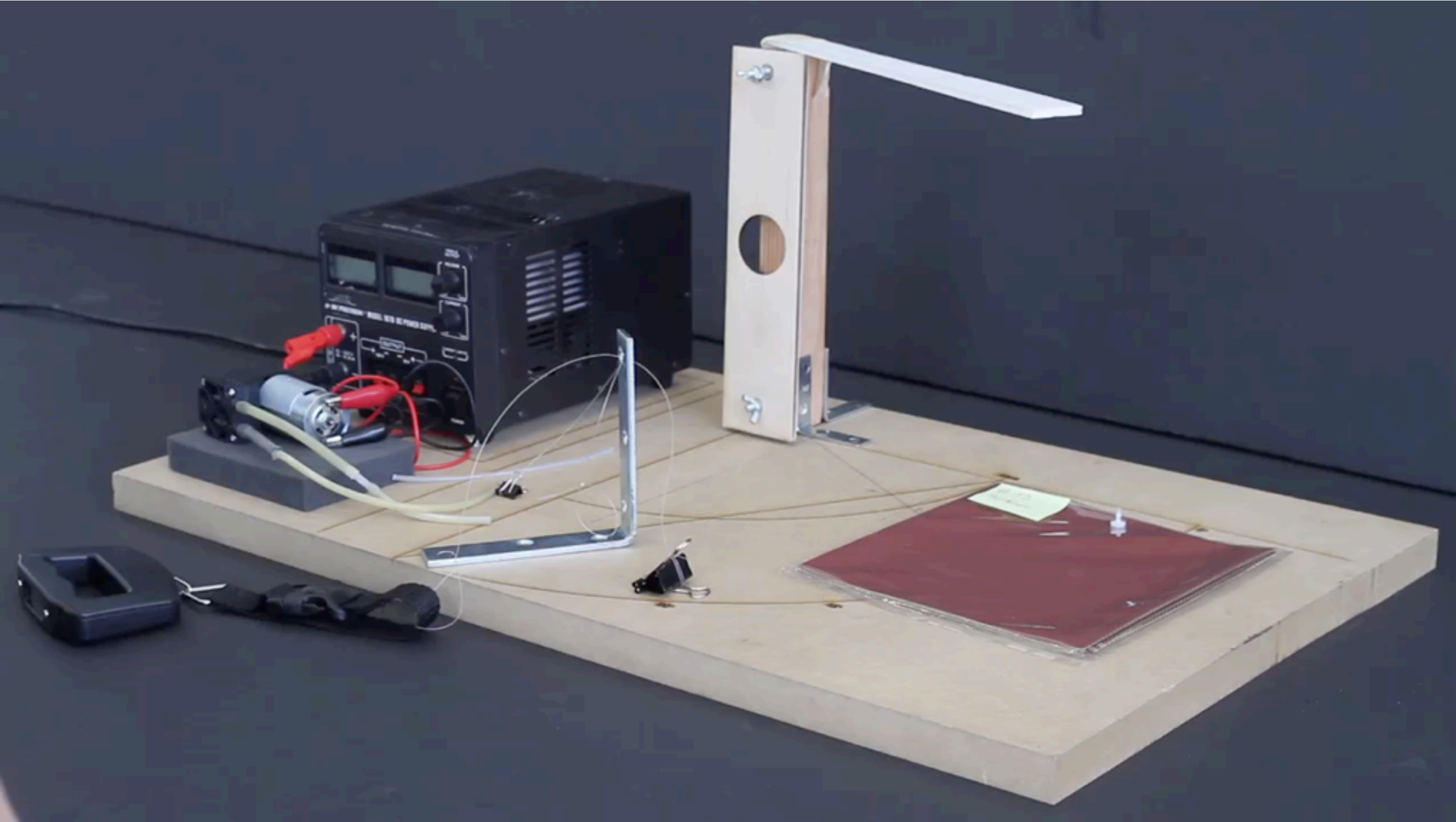

Sheet-Materials

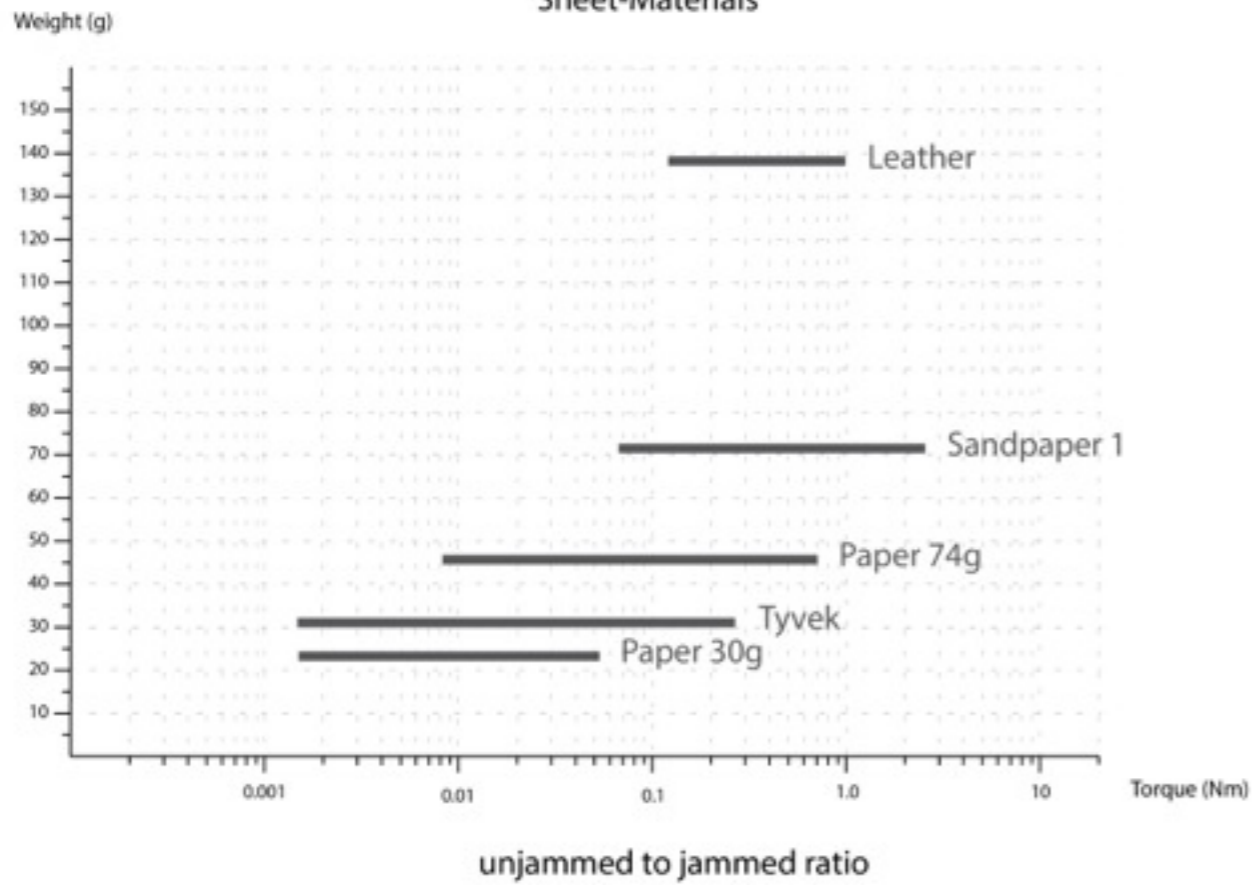

Sheet-Materials

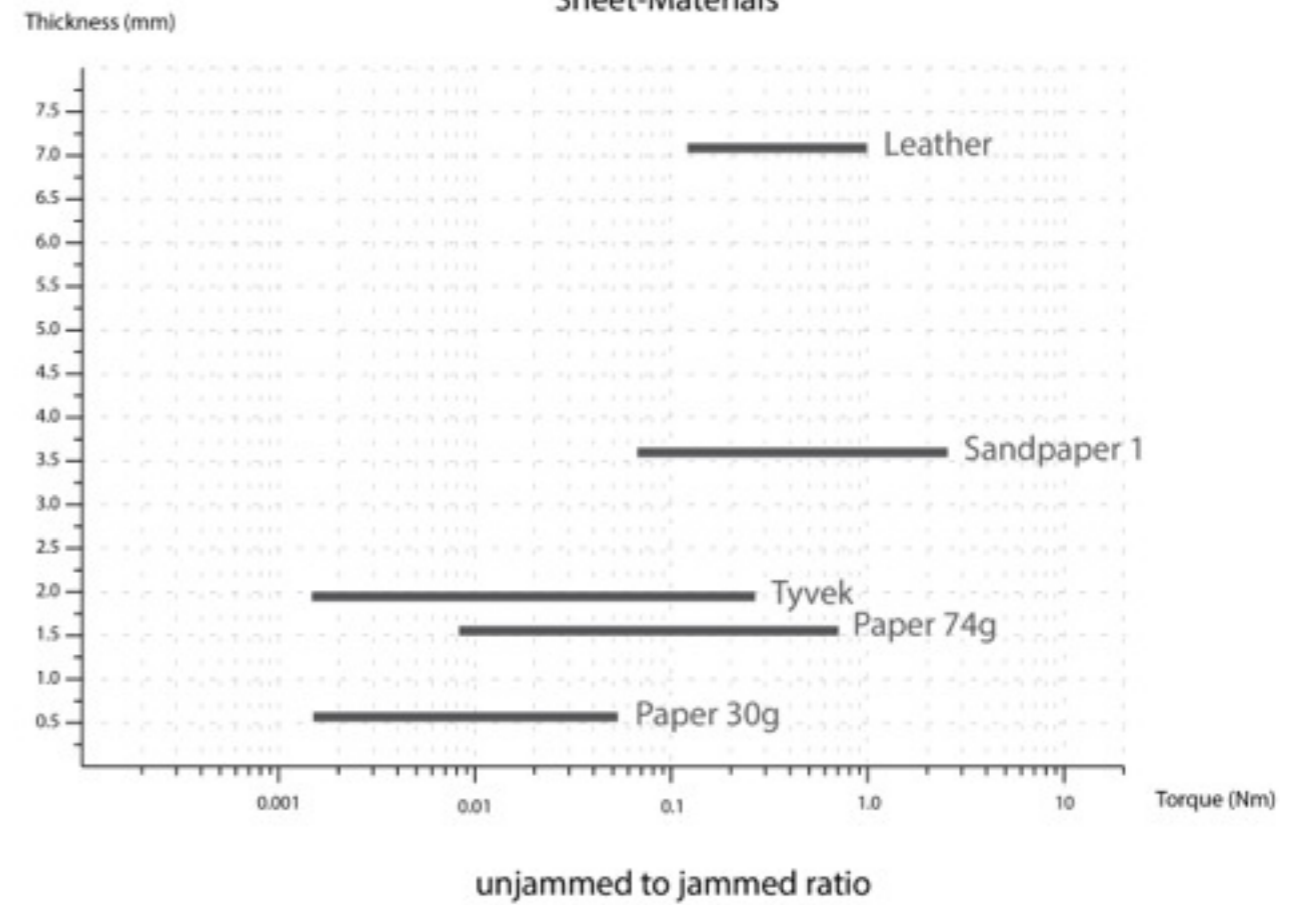

LIMITATIONS

1. Tethered system
2. Trade of between weight and power of vacuum pump
3. requires air tight



Eames Lounge Chair Wood
image from internet

Future Application Scope

Computer Devices

Display/Electronics



On-body/Indoor

Wearable/Furniture



Outdoor

Sails/Windturbine



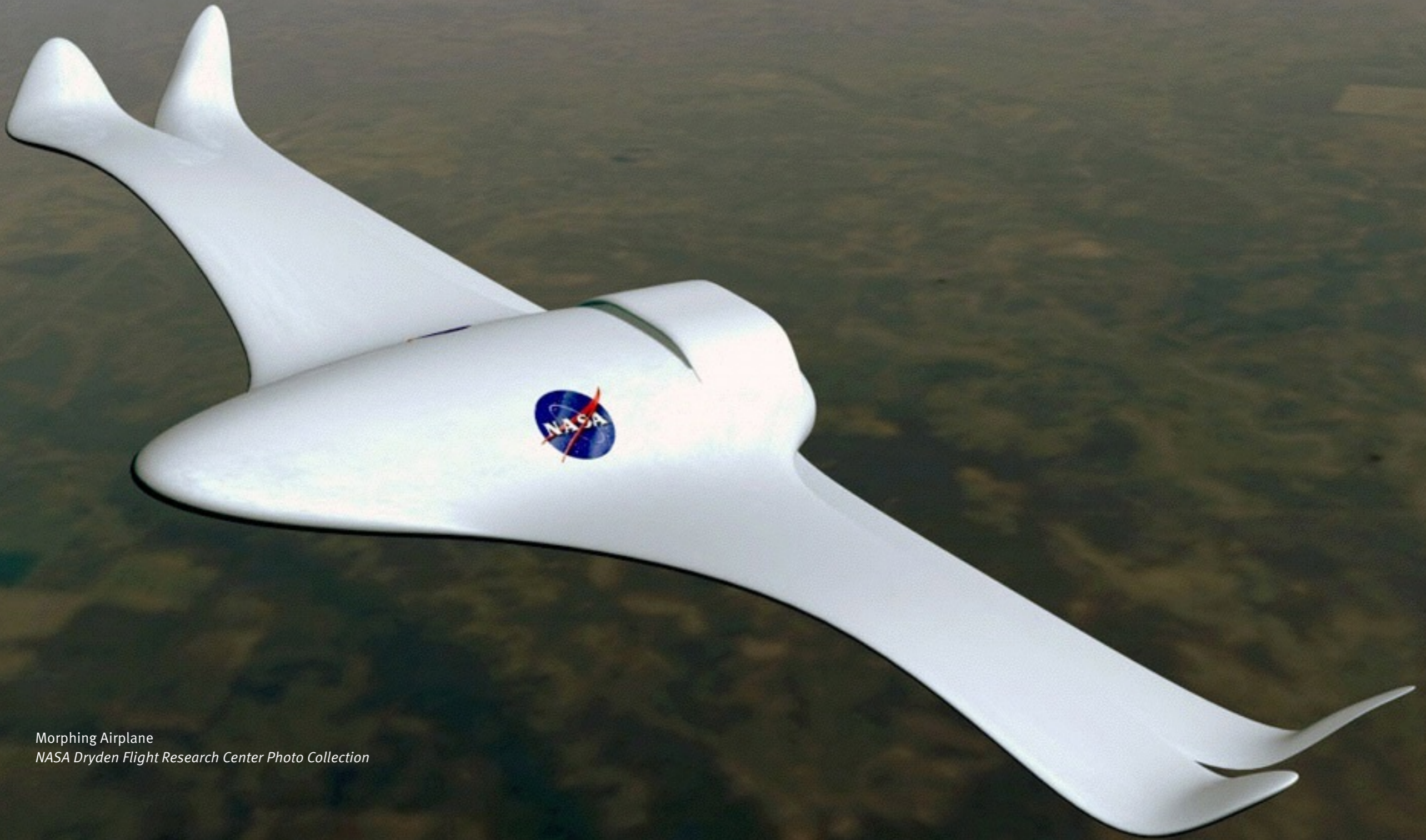

Morphing Airplane
NASA Dryden Flight Research Center Photo Collection

How Pixels Represent Information



How Materials Represent Information



How Materials **Become** Information

Controlling Material Properties

Optical Properties

color, opacity, reflectivity, luminosity

Surface Properties

texture

Thermal Properties

temperature, specific heat, thermal conductivity

Mechanical Properties

plasticity, elasticity, hardness, density, coefficient of friction, **stiffness**

Electro/Magnetic Properties

conductivity, dielectric properties



the inevitable coalescence between materialization and computation

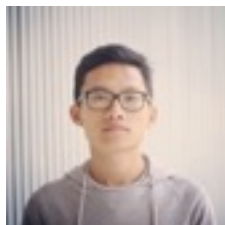
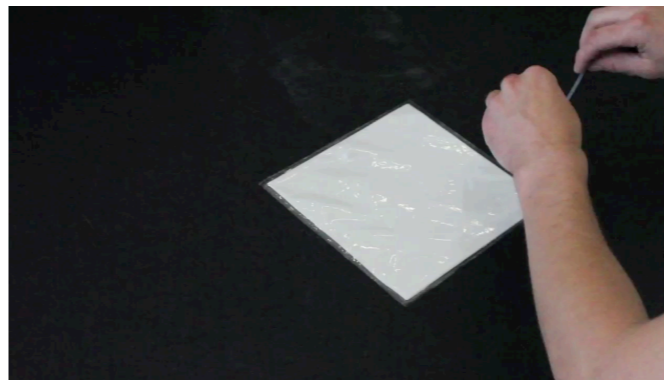
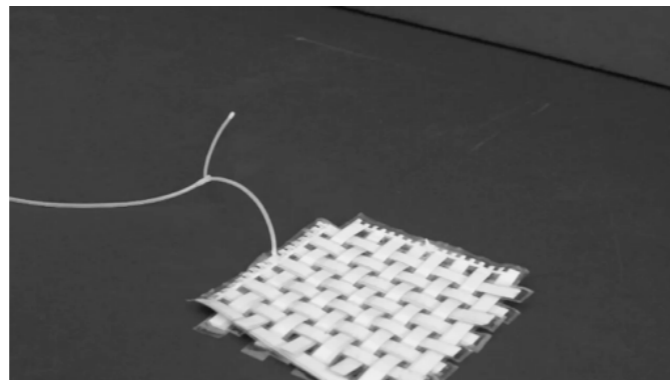
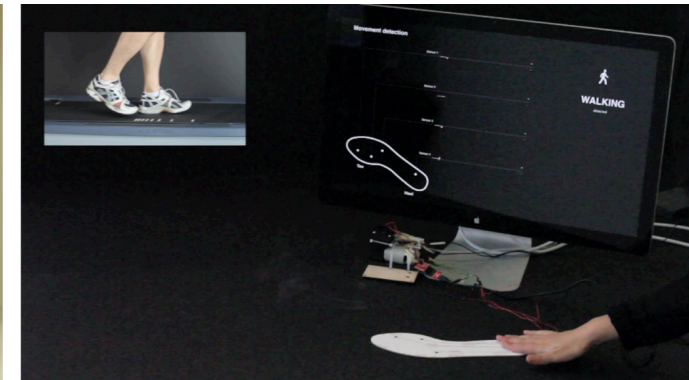
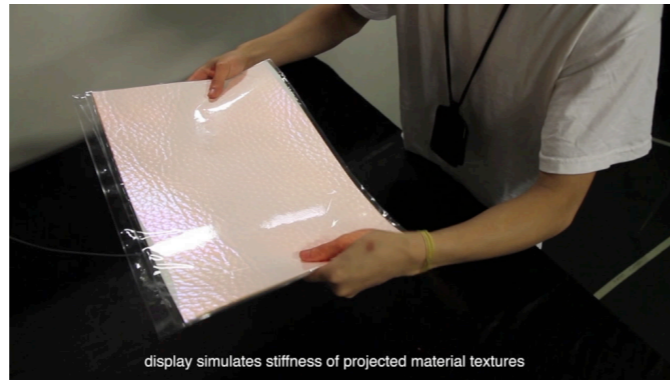

THANK YOU!

Jifei Ou¹, Lining Yao¹, Daniel Tauber², Jürgen Steimle³, Ryuma Niiyama¹, Hiroshi Ishii¹

1. MIT Media Lab, USA; 2. Royal College of Art, UK; 3. Max Planck Institute for Informatics, Germany