

MAS836 – Sensor Technologies for Interactive Environments



Lecture 3 – Analog Conditioning Electronics, Pt. 3

Nonlinear Signal Shaping

Amplitude Compression

- Diode Shapers
- Log Amps
- Componders
- Analog Multipliers
 - Squaring and square-rooting

$$V_{BE} = \frac{KT}{q} \log_e \left(\frac{I_c}{I_0} \right)$$

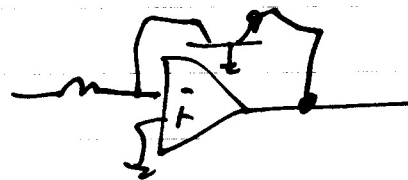

$$V_o = \frac{KT}{q} \log_e \left(\frac{I_c}{I_0} \right)$$

Transdiode $I_c = -V_{in}/R$

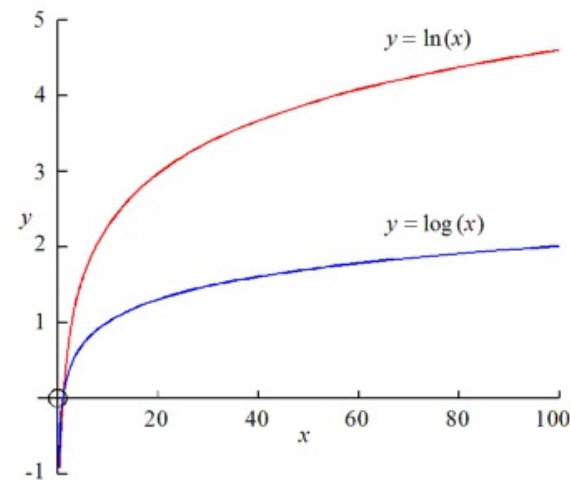

Log Amplifiers



Burr-Brown Products
from Texas Instruments

LOG101



SBO5242A - MAY 2002 - REVISED APRIL 2003

Precision LOGARITHMIC AND LOG RATIO AMPLIFIER

FEATURES

- EASY-TO-USE COMPLETE CORE FUNCTION
- HIGH ACCURACY: 0.01% FSO Over 5 Decades
- WIDE INPUT DYNAMIC RANGE:
7.5 Decades, 100pA to 3.5mA
- LOW QUIESCENT CURRENT: 1mA
- WIDE SUPPLY RANGE: $\pm 4.5V$ to $\pm 18V$

APPLICATIONS

- LOG, LOG RATIO, ANTI-LOG COMPUTATION:
Communication, Analytical, Medical, Industrial,
Test, and General Instrumentation
- PHOTODIODE SIGNAL COMPRESSION AMPS
- ANALOG SIGNAL COMPRESSION IN FRONT
OF ANALOG-TO-DIGITAL (A/D) CONVERTERS

DESCRIPTION

The LOG101 is a versatile integrated circuit that computes the logarithm or log ratio of an input current relative to a reference current.

The LOG101 is tested over a wide dynamic range of input signals. In log ratio applications, a signal current can come from a photodiode, and a reference current from a resistor in series with a precision external reference.

The output signal at V_{OUT} is trimmed to 1V per decade of input current allowing seven decades of input current dynamic range.

Low DC offset voltage and temperature drift allow accurate measurement of low-level signals over a wide environmental temperature range. The LOG101 is specified over the temperature range $-5^{\circ}C$ to $+75^{\circ}C$, with operation over $-40^{\circ}C$ to $+85^{\circ}C$.

Note: US Patent Pending

*Extra transistor &
thermal resistor
integrated for temp.
compensation*

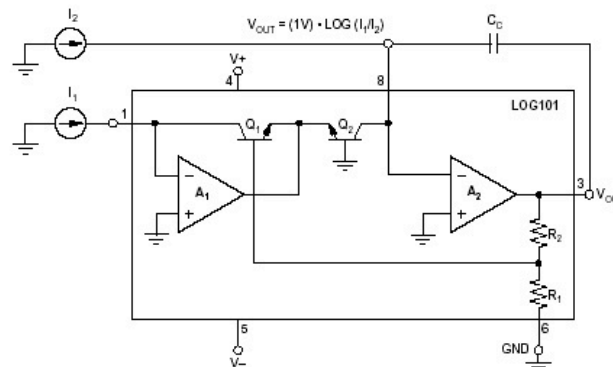

Smoothly
limit
(compress)
the amplitude
of a signal

Diode Triangle-to-Sine Waveshaper

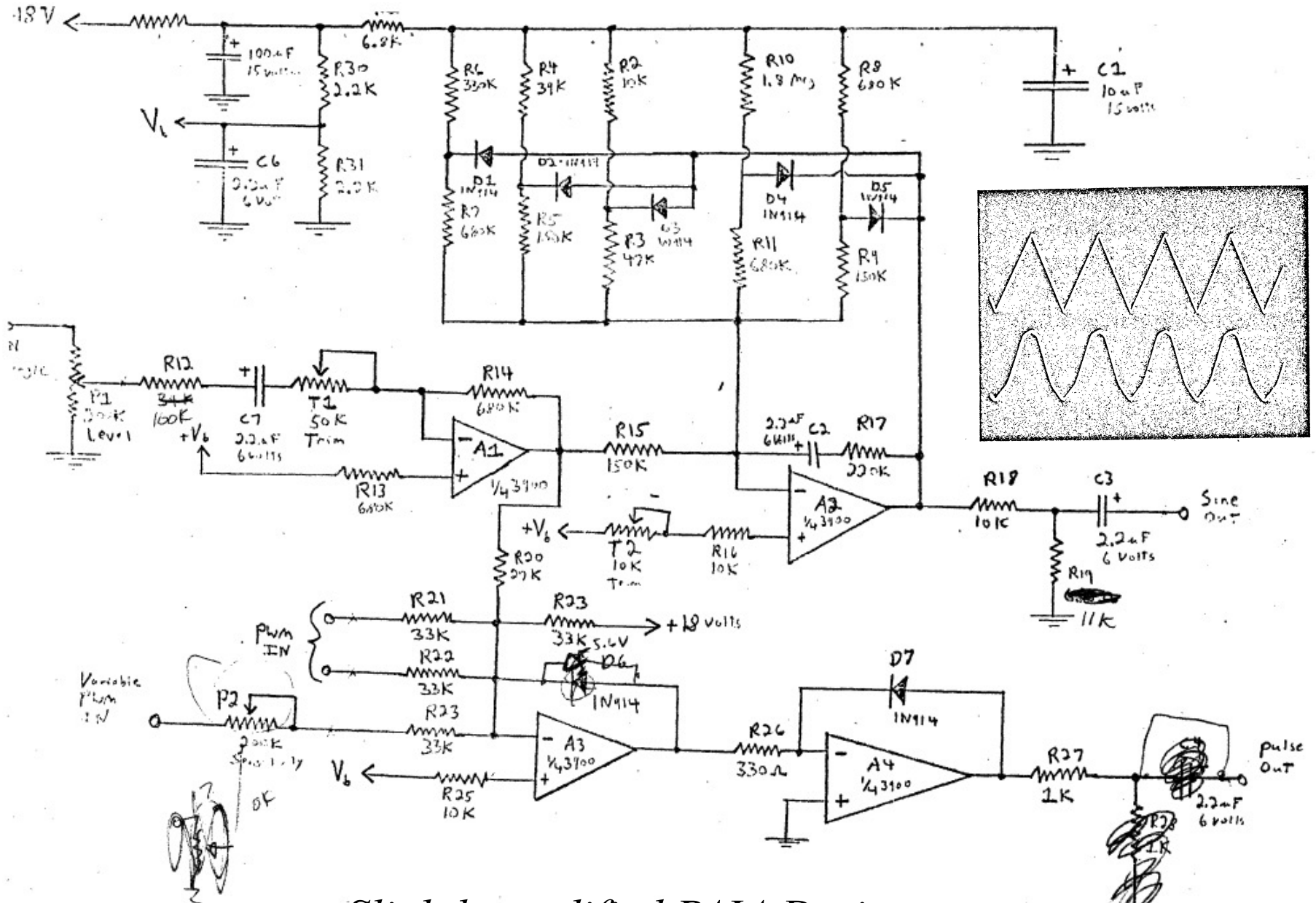

Slightly modified PAIA Design

Compunder (compressor/expander)

Philips Semiconductors

Product data

Compunder

NE570 and NE571

GENERAL DESCRIPTION

The NE570 is a versatile low cost dual gain control circuit in which either channel may be used as a dynamic range compressor or expander. Each channel has a full-wave rectifier to detect the average value of the signal, a linearized temperature-compensated variable gain cell, and an operational amplifier.

The NE570 is well suited for use in cellular radio and radio communications systems, modems, telephone, and satellite broadcast/receive audio systems.

FEATURES

- Complete compressor and expander in one IC
- Temperature compensated
- Greater than 110 dB dynamic range
- Operates down to 6 V_{DC}
- System levels adjustable with external components
- Distortion may be trimmed out

APPLICATIONS

- Cellular radio
- Telephone trunk comander
- High level limiter
- Low level expander—noise gate
- Dynamic noise reduction systems
- Voltage-controlled amplifier
- Dynamic filters

ORDERING INFORMATION

Type number	Package			Temperature range
	Name	Description	Version	
NE570D	SO16	plastic small outline package; 16 leads; body width 7.5 mm	SOT162-1	0 °C to +70 °C

PIN CONFIGURATION

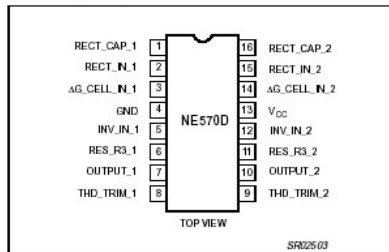

Figure 1. Pin configuration.

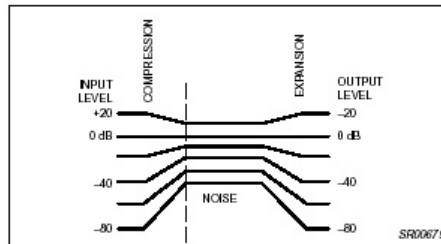

Figure 5. Restricted dynamic range channel

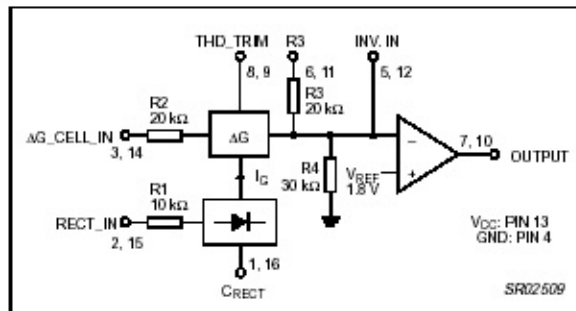
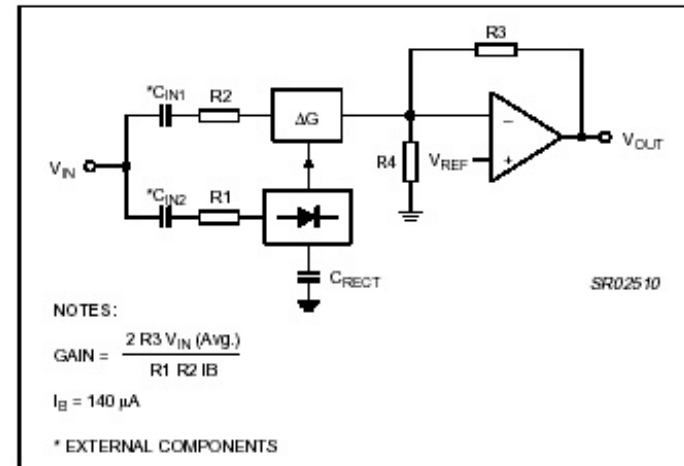

Figure 6. Chip block diagram (1 of 2 channels)



NOTES:

$$\text{GAIN} = \frac{2 R_3 V_{IN} (\text{Avg.})}{R_1 R_2 I_B}$$

$$I_B = 140 \mu\text{A}$$

* EXTERNAL COMPONENTS

Figure 7. Basic expander

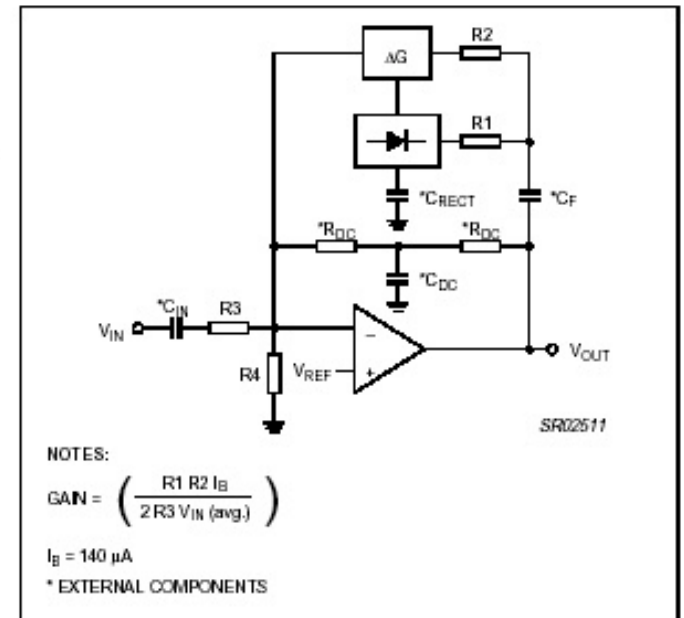

NOTES:

$$\text{GAIN} = \left(\frac{R_1 R_2 I_B}{2 R_3 V_{IN} (\text{avg.})} \right)$$

$$I_B = 140 \mu\text{A}$$

* EXTERNAL COMPONENTS

Figure 8. Basic compressor

*Compress or
expand the
envelope of an
AC signal*

Digitally Controlled Potentiometer

- MAX 5161
 - Low Power (100 nA) up to 200K ohms, 32 taps

Features

- ◆ 32 Tap Positions
- ◆ 50k Ω , 100k Ω , and 200k Ω Resistance Values
- ◆ 400 Ω Wiper Resistance
- ◆ $\pm 25\%$ Resistance Tolerance
- ◆ 3-Wire Serial Data Input
- ◆ ± 1 LSB DNL
- ◆ ± 0.5 LSB INL
- ◆ 100nA Supply Current
- ◆ +2.7V to +5.5V Single-Supply Operation
- ◆ Power-On Reset: Wiper Goes to Midscale (position 16)
- ◆ ± 2 kV ESD Protection
- ◆ Small-Footprint Packages
 - 6-Pin SOT23 (MAX5161)
 - 8-Pin μ MAX (MAX5160)
- ◆ Glitchless Switching Between the Resistor Taps

Pin Configurations

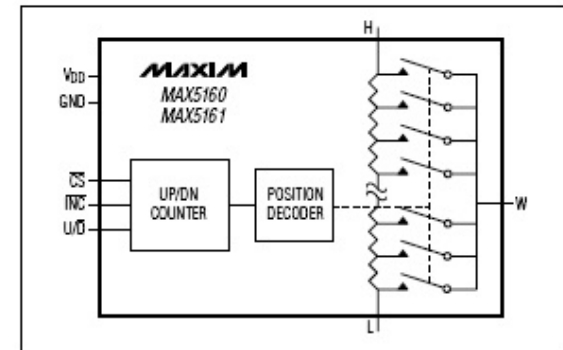
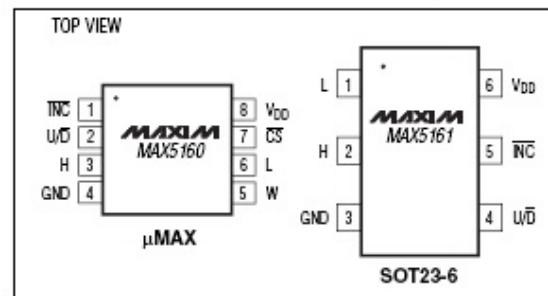

MAXIM

Maxim Integrated Products 1

Digitization

- Can use an analog-digital converter (ADC)
 - 8-12 bit converters commonly on μ Computers
 - Sometimes 16 or 24 bit (μ Converter from Analog)
 - For special applications, one can use an ADC chip
 - Typically talk SPI, I²C, etc.
 - Many kinds of ADC
 - Pipeline, Successive Approximation, Flash, $\Sigma\Delta$...
 - Ari will tell you lots about how these work and their characteristics
- For just 1 or 2 bits, you can use comparators
 - Comparitors often on μ C chip too
- You can also convert an amplitude into a time signal
 - Only need a logic pin and a timing routine (or internal μ C timer)
 - Voltage to pulse-width, voltage to frequency
 - Can do current too!

Pulse Encoding

- The astable multivibrator
 - VCO (voltage controlled oscillator)
 - PWM (pulse-width modulation)

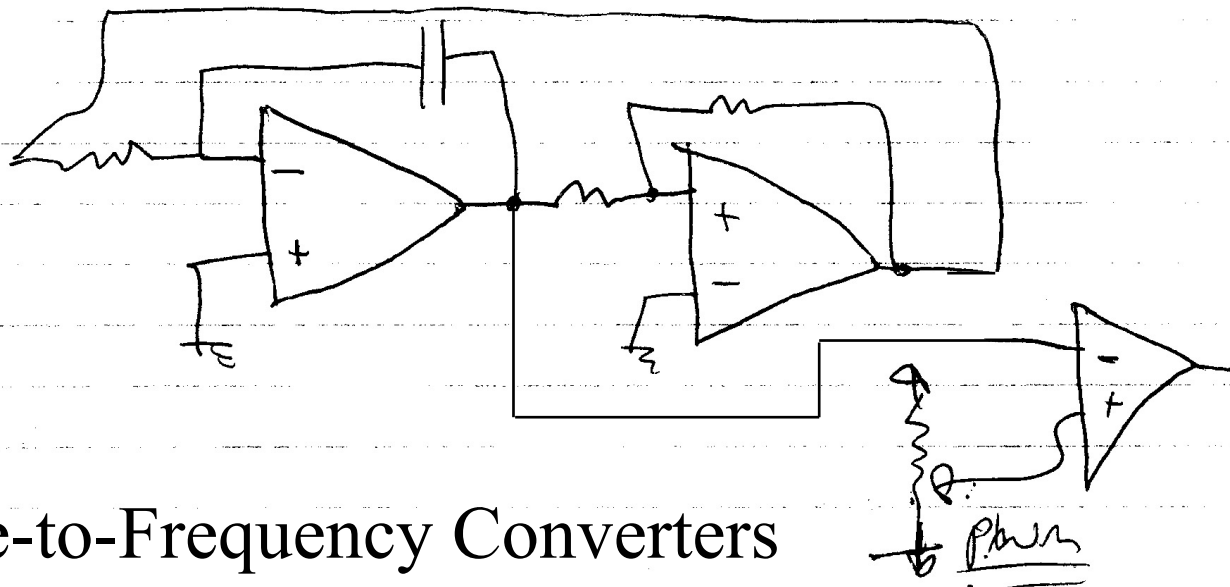

- Voltage-to-Frequency Converters
- Using the 555 as a Voltage-to-PW converter

How do I make this into a VCO?

What kind of waveform(s) does this produce?

Voltage-to-Frequency Converters

LM231A/LM231/LM331A/LM331 Precision Voltage-to-Frequency Converters

General Description

The LM231/LM331 family of voltage-to-frequency converters are ideally suited for use in simple low-cost circuits for analog-to-digital conversion, precision frequency-to-voltage conversion, long-term integration, linear frequency modulation or demodulation, and many other functions. The output when used as a voltage-to-frequency converter is a pulse train at a frequency precisely proportional to the applied input voltage. Thus, it provides all the inherent advantages of the voltage-to-frequency conversion techniques, and is easy to apply in all standard voltage-to-frequency converter applications. Further, the LM231A/LM331A attain a new high level of accuracy versus temperature which could only be attained with expensive voltage-to-frequency modules. Additionally the LM231/331 are ideally suited for use in digital systems at low power supply voltages and can provide low-cost analog-to-digital conversion in microprocessor-controlled systems. And, the frequency from a battery powered voltage-to-frequency converter can be easily channeled through a simple photoisolator to provide isolation against high common mode levels.

The LM231/LM331 utilize a new temperature-compensated band-gap reference circuit, to provide excellent accuracy

over the full operating temperature range, at power supplies as low as 4.0V. The precision timer circuit has low bias currents without degrading the quick response necessary for 100 kHz voltage-to-frequency conversion. And the output are capable of driving 3 TTL loads, or a high voltage output up to 40V, yet is short-circuit-proof against V_{CC} .

Features

- Guaranteed linearity 0.01% max
- Improved performance in existing voltage-to-frequency conversion applications
- Split or single supply operation
- Operates on single 5V supply
- Pulse output compatible with all logic forms
- Excellent temperature stability, ± 50 ppm/ $^{\circ}$ C max
- Low power dissipation, 15 mW typical at 5V
- Wide dynamic range, 100 dB min at 10 kHz full scale frequency
- Wide range of full scale frequency, 1 Hz to 100 kHz
- Low cost

LM566 is a triangle-pulse VCO

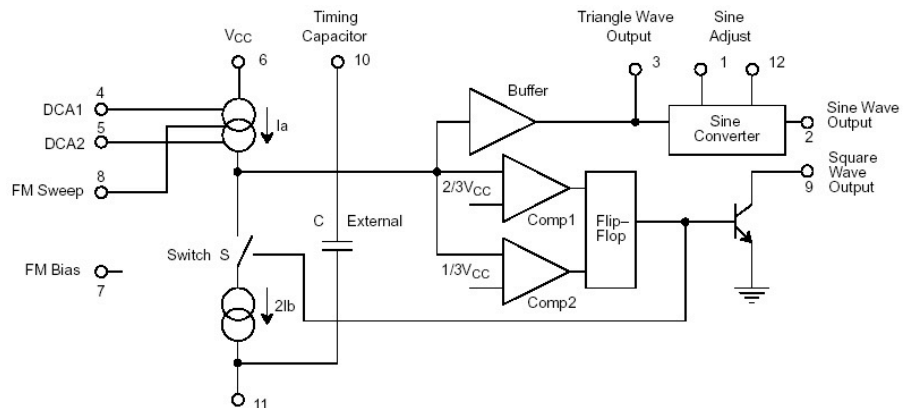

Typical Applications

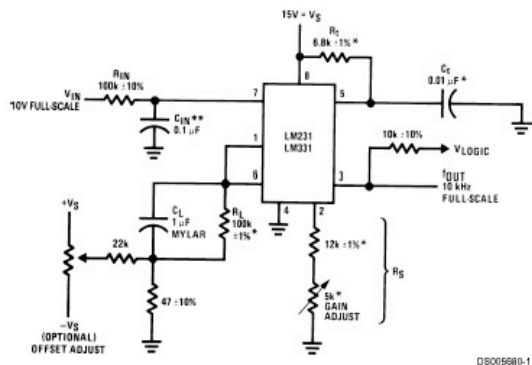

$$f_{OUT} = \frac{V_{IN}}{2.09 V} \cdot \frac{R_S}{R_L} \cdot \frac{1}{R_1 C_1}$$

*Use stable components with low temperature coefficients. See Typical Applications section.

**0.1μF or 1μF. See "Principles of Operation."

FIGURE 1. Simple Stand-Alone Voltage-to-Frequency Converter with $\pm 0.03\%$ Typical Linearity ($f = 10$ Hz to 11 kHz)

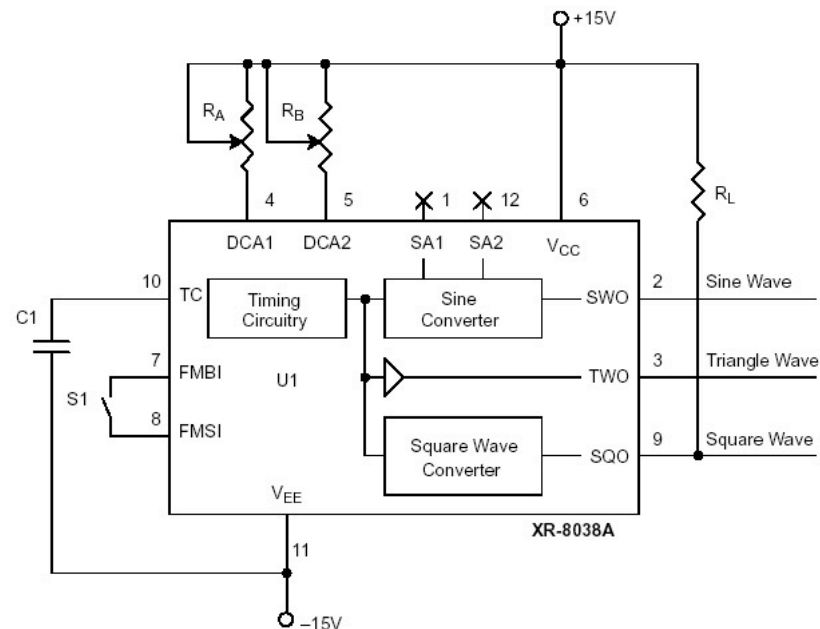

XR8038A VCO Function Generator

The 555 Timer (556 is dual version)

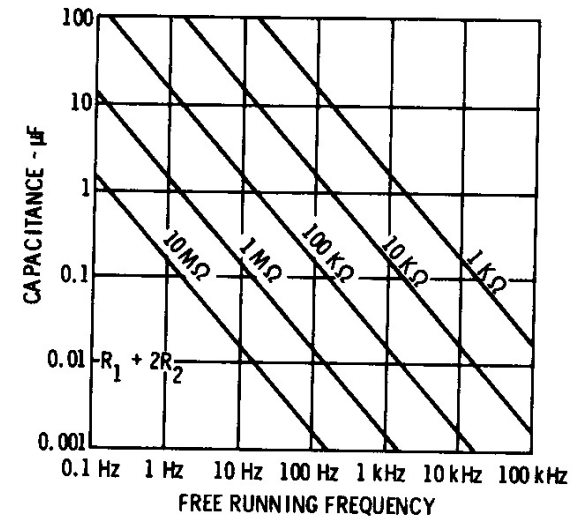
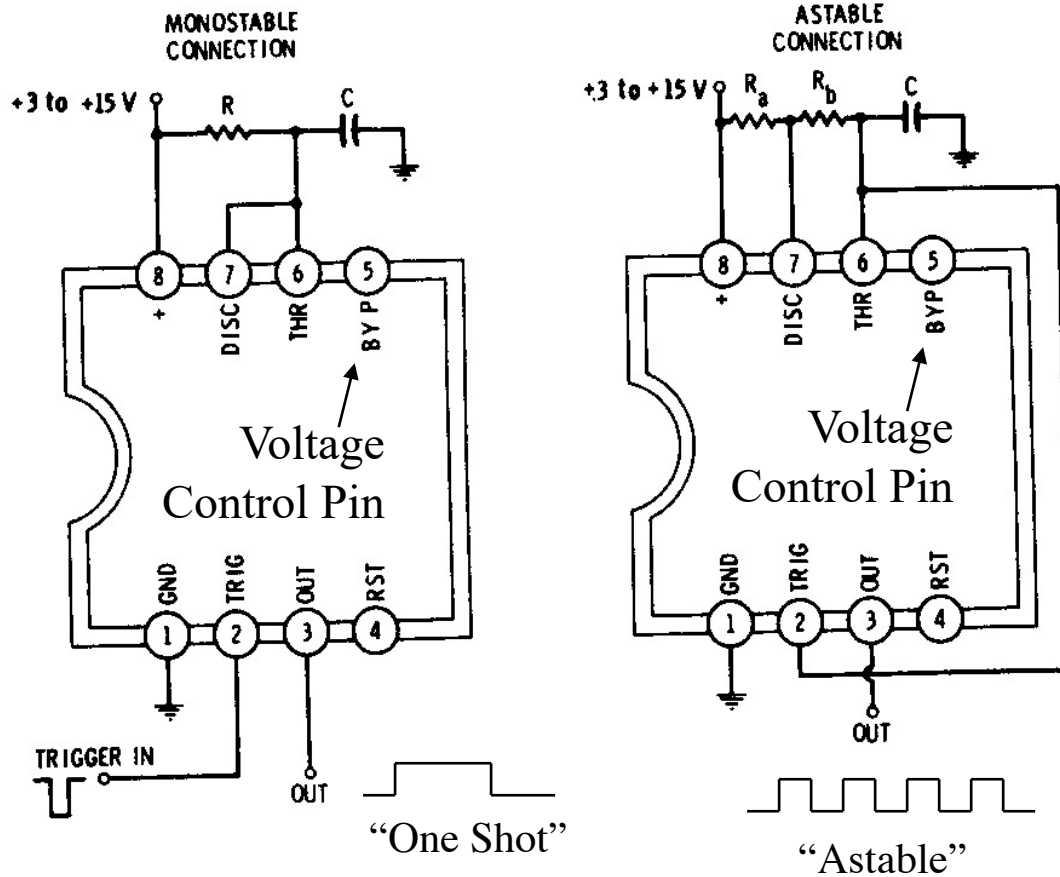

(A) Graph of R₁, R₂, C, and operating frequency.

CHARGE TIME (OUTPUT HIGH):	$0.693 (R_1 + R_2) C$
DISCHARGE TIME (OUTPUT LOW):	$0.693 (R_2) C$
PERIOD:	$0.693 (R_1 + 2R_2) C$
FREQUENCY:	$\frac{1.44}{(R_1 + 2R_2) C}$
LIMITS:	MAX $R_1 + R_2$ -- 3.3 meg MIN R_1 OR R_2 -- 1 K MIN RECOMMENDED CAPACITANCE: 500 pF MAX CAPACITANCE -- LIMITED BY C LEAKAGE
DUTY CYCLE:	$= \frac{\text{TIME HIGH}}{\text{TIME LOW}} = \frac{R_1 + R_2}{R_2}$

(B) Design equations.

Extremely versatile and cheap (and old!) module

Low power version (L555 or 555L)

Normal version does hours - 1 microsec

Can voltage-control the pulse period (nonlinear)

Triggering a monostable from a clock provides a voltage-variable periodic pulse (that can be timed in a microprocessor)

Analog Multipliers (4-Quadrant)



Low Cost
Analog Multiplier

AD633

FEATURES

4-Quadrant Multiplication
Low Cost 8-Lead Package
Complete—No External Components Required
Laser-Trimmed Accuracy and Stability
Total Error within 2% of FS
Differential High Impedance X and Y Inputs
High Impedance Unity-Gain Summing Input
Laser-Trimmed 10 V Scaling Reference

APPLICATIONS

Multiplication, Division, Squaring
Modulation/Demodulation, Phase Detection
Voltage Controlled Amplifiers/Attenuators/Filters

PRODUCT DESCRIPTION

The AD633 is a functionally complete, four-quadrant, analog multiplier. It includes high impedance, differential X and Y inputs and a high impedance summing input (Z). The low impedance output voltage is a nominal 10 V full scale provided by a buried Zener. The AD633 is the first product to offer these features in modestly priced 8-lead plastic DIP and SOIC packages.

The AD633 is laser calibrated to a guaranteed total accuracy of 2% of full scale. Nonlinearity for the Y input is typically less than 0.1% and noise referred to the output is typically less than 100 μV rms in a 10 Hz to 10 kHz bandwidth. A 1 MHz bandwidth, 20 V/ μs slew rate, and the ability to drive capacitive loads make the AD633 useful in a wide variety of applications where simplicity and cost are key concerns.

The AD633's versatility is not compromised by its simplicity. The Z-input provides access to the output buffer amplifier, enabling the user to sum the outputs of two or more multipliers, increase the multiplier gain, convert the output voltage to a current, and configure a variety of applications.

The AD633 is available in an 8-lead plastic DIP package (N) and 8-lead SOIC (R). It is specified to operate over the 0°C to 70°C commercial temperature range (J Grade) or the -40°C to +85°C industrial temperature range (A Grade).

CONNECTION DIAGRAMS

8-Lead Plastic DIP (N) Package

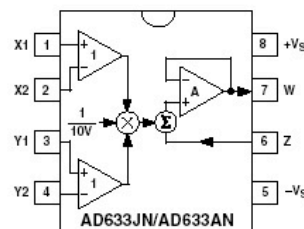

8-Lead Plastic SOIC (RN-8) Package

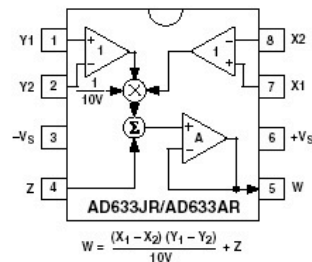

PRODUCT HIGHLIGHTS

1. The AD633 is a complete four-quadrant multiplier offered in low cost 8-lead plastic packages. The result is a product that is cost effective and easy to apply.
2. No external components or expensive user calibration are required to apply the AD633.
3. Monolithic construction and laser calibration make the device stable and reliable.
4. High (10 M Ω) input resistances make signal source loading negligible.
5. Power supply voltages can range from ± 8 V to ± 18 V. The internal scaling voltage is generated by a stable Zener diode; multiplier accuracy is essentially supply insensitive.

This is a cheap one
\$5 or so apiece

They get much
more expensive
with more
bandwidth and
accuracy

4-Quadrant flips phase w. sign

*2-Quadrant multiplies |X|•Y
only changes gain*

Synchronous Detection

- Also called a "Lock-in" Amplifier
- Also a "Matched Filter" of sorts
- Can regenerate carrier with PLL if no connection

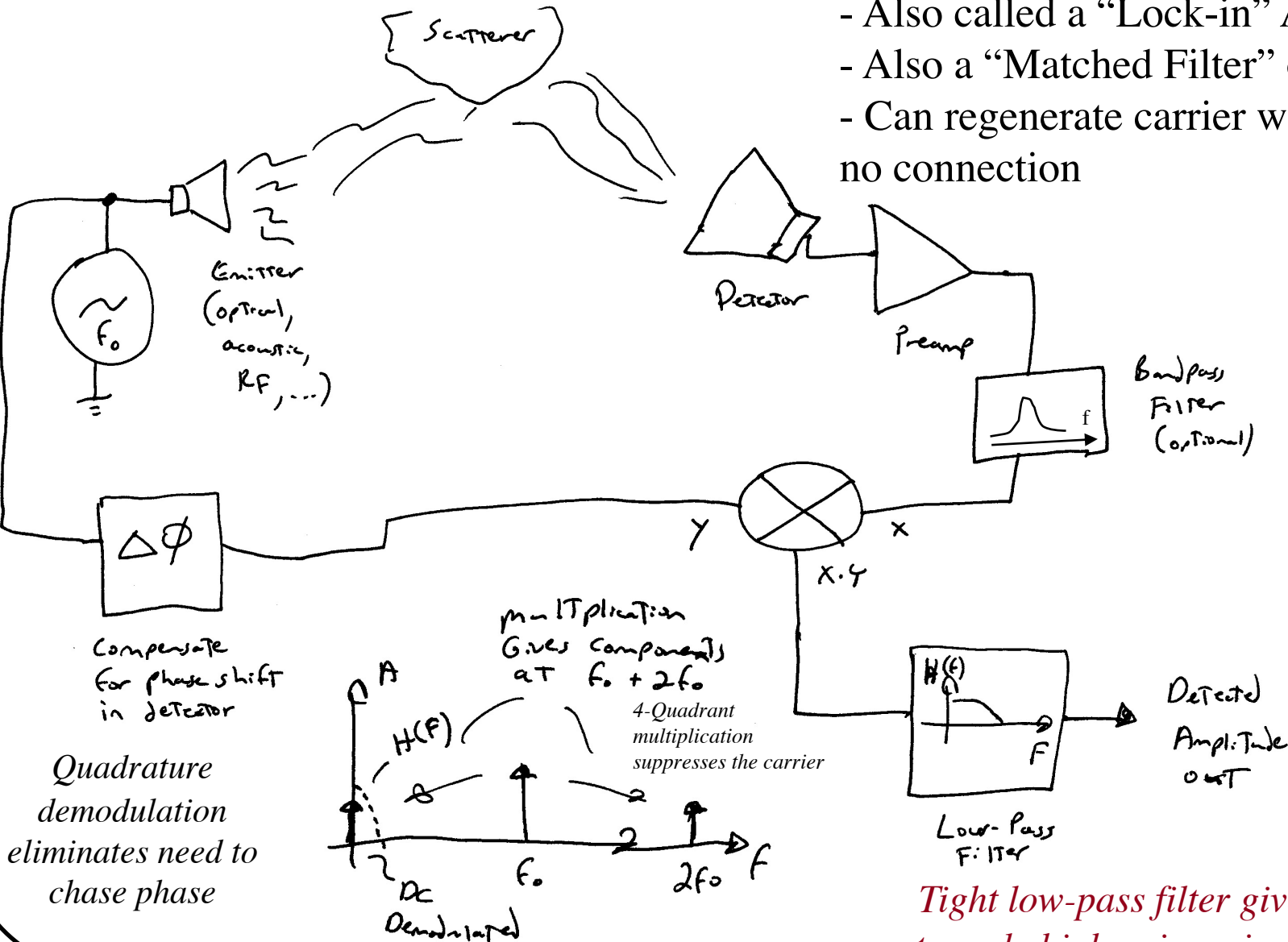

Tight low-pass filter gives extremely high noise rejection!

Demodulating with a switch (Walsh Waves)

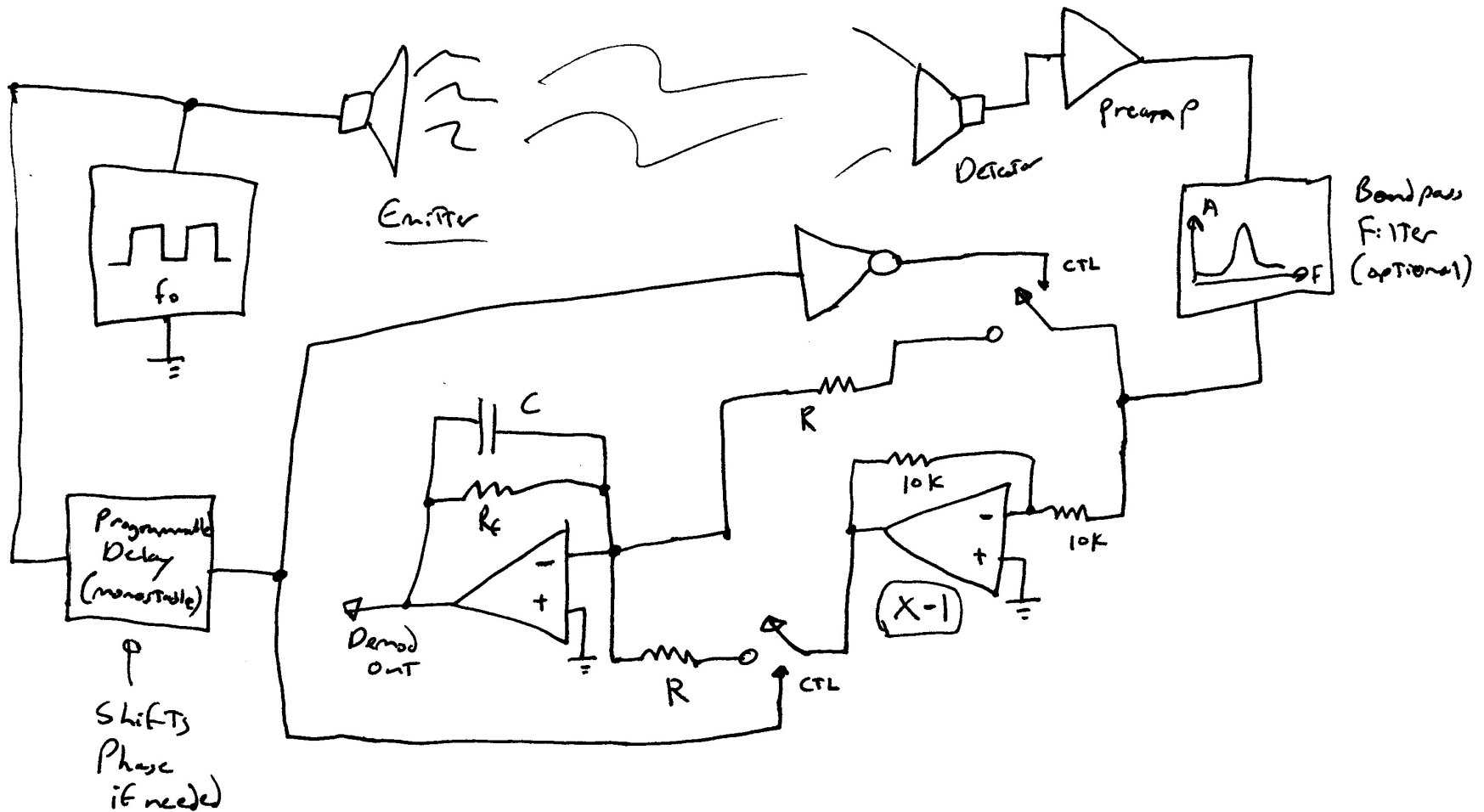

Cheaper, and sometimes more accurate than using a multiplier

Some analog switches have the built-in inverter

Can use instrumentation amplifier (w. passive filters on inputs) to subtract on from off

If μP is fast enough, this can be done digitally (dynamic range in sum?)

Buy it as the AD630



Balanced Modulator/Demodulator

AD630

FEATURES

Recovers Signal from +100 dB Noise
 2 MHz Channel Bandwidth
 45 V/ μ s Slew Rate
 -120 dB Crosstalk @ 1 kHz
 Pin Programmable Closed Loop Gains of ± 1 and ± 2
 0.05% Closed Loop Gain Accuracy and Match
 100 μ V Channel Offset Voltage (AD630BD)
 350 kHz Full Power Bandwidth
 Chips Available

PRODUCT DESCRIPTION

The AD630 is a high precision balanced modulator which combines a flexible commutating architecture with the accuracy and temperature stability afforded by laser wafer trimmed thin-film resistors. Its signal processing applications include balanced modulation and demodulation, synchronous detection, phase detection, quadrature detection, phase sensitive detection, lock-in amplification and square wave multiplication. A network of on-board applications resistors provides precision closed loop gains of ± 1 and ± 2 with 0.05% accuracy (AD630B). These resistors may also be used to accurately configure multiplexer gains of +1, +2, +3 or +4. Alternatively, external feedback may be employed allowing the designer to implement his own high gain or complex switched feedback topologies.

The AD630 may be thought of as a precision op amp with two independent differential input stages and a precision comparator which is used to select the active front end. The rapid response time of this comparator coupled with the high slew rate and fast settling of the linear amplifiers minimize switching distortion. In addition, the AD630 has extremely low crosstalk between channels of -100 dB @ 10 kHz.

The AD630 is intended for use in precision signal processing and instrumentation applications requiring wide dynamic range. When used as a synchronous demodulator in a lock-in amplifier configuration, it can recover a small signal from 100 dB of interfering noise (see lock-in amplifier application). Although optimized for operation up to 1 kHz, the circuit is useful at frequencies up to several hundred kilohertz.

Other features of the AD630 include pin programmable frequency compensation, optional input bias current compensation resistors, common-mode and differential-offset voltage adjustment, and a channel status output which indicates which of the two differential inputs is active. This device is now available to Standard Military Drawing (DESC) numbers 5962-8980701RA and 5962-89807012A.

FUNCTIONAL BLOCK DIAGRAM

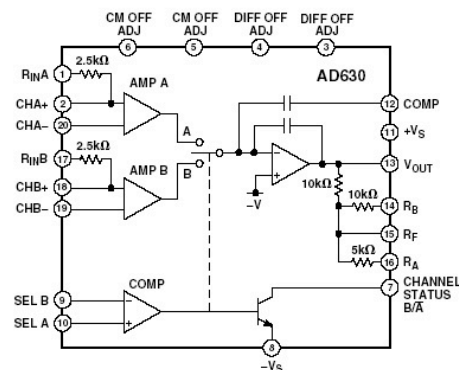

PRODUCT HIGHLIGHTS

1. The configuration of the AD630 makes it ideal for signal processing applications such as: balanced modulation and demodulation, lock-in amplification, phase detection, and square wave multiplication.
2. The application flexibility of the AD630 makes it the best choice for many applications requiring precisely fixed gain, switched gain, multiplexing, integrating-switching functions, and high-speed precision amplification.
3. The 100 dB dynamic range of the AD630 exceeds that of any hybrid or IC balanced modulator/demodulator and is comparable to that of costly signal processing instruments.
4. The op-amp format of the AD630 ensures easy implementation of high gain or complex switched feedback functions. The application resistors facilitate the implementation of most common applications with no additional parts.
5. The AD630 can be used as a two channel multiplexer with gains of +1, +2, +3, or +4. The channel separation of 100 dB @ 10 kHz approaches the limit which is achievable with an empty IC package.
6. The AD630 has pin-strappable frequency compensation (no external capacitor required) for stable operation at unity gain without sacrificing dynamic performance at higher gains.
7. Laser trimming of comparator and amplifying channel offsets eliminates the need for external nulling in most cases.

Cross Correlation and Matched Filters

Stored "Transmitted" Reference Signal

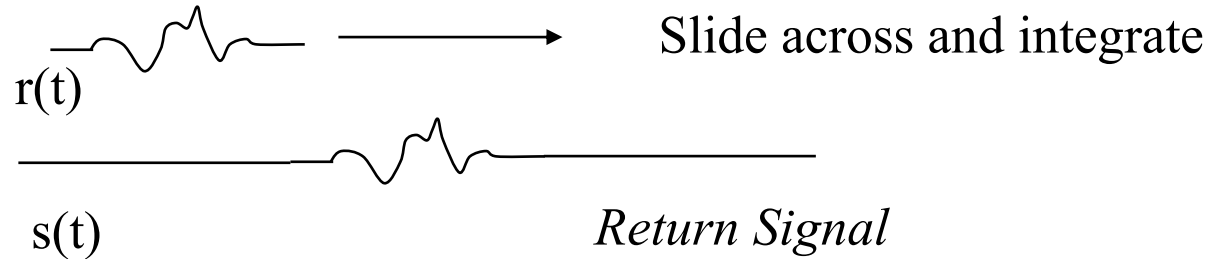

$$z(t) = \int_{-\infty}^{+\infty} s(\delta-t) \cdot r(\delta) d\delta$$

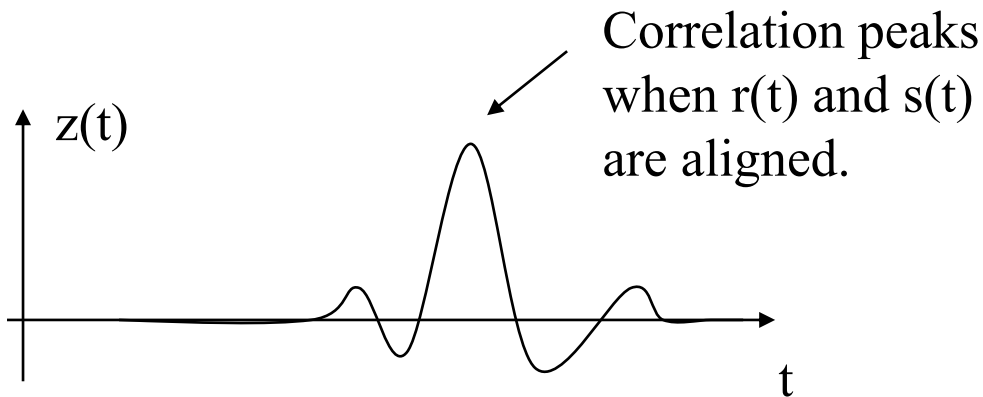

Implementation in sonar or radar

Send Coded Ping

$\Delta t = 2d/c$ (d is distance from co-located transmitter and receiver)

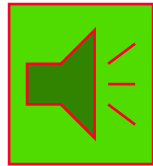

Transmitter

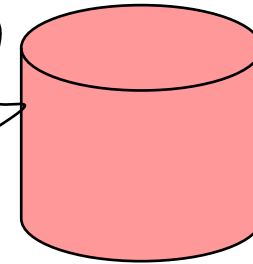

Object

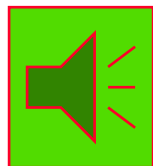

Receiver

Store received ping
and run cross correlation

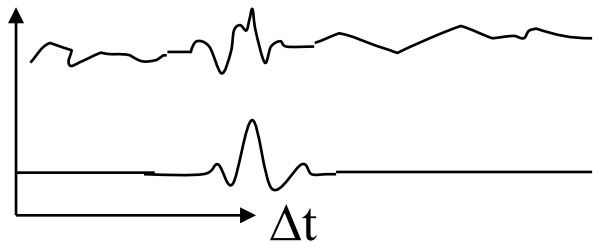

Received Signal (stored in buffer)

Correlator Output

Sources of Noise in Electronics

- Johnson (or Nyquist) Noise *10K resistor @ room temp develops 1.3 μ V over decade in frequency*
 - Flat spectrum
 - $V_{\text{noise}} = \sqrt{4kTR[\Delta f]}$
 - Independent of current
 - Comes from the fluxuation-dissipation theorem
- Flicker Noise
 - 1/f spectrum (equal power per decade of frequency)
 - Increases with current through element
 - Due to nonidealities (or “granularity”) in component

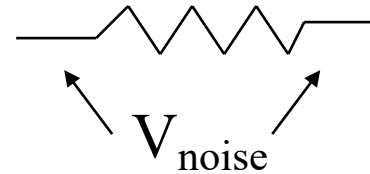

Flicker noise in different kinds of resistors:

rms microvolts per volt applied across the resistor, measured over one decade of frequency:

Carbon-composition	0.10 μ V to 3.0 μ V
Carbon-film	0.05 μ V to 0.3 μ V
Metal-film	0.02 μ V to 0.2 μ V
Wire-wound	0.01 μ V to 0.2 μ V

Shot Noise

- Shot (or Quantization) noise
 - “Rain on the Roof” - when each electron does something different
 - Prevalent where electrons cross a barrier
 - Diodes, transistors
 - Not in wires, less in resistors
 - $I_{\text{noise}} = \sqrt{2qI_{\text{dc}}\Delta f}$ (charges acting independently)
 - *Proportionally* worse with small current
 - Flat spectrum
- Popcorn noise
 - Periodic spikes in signal
 - These days, typically a bad component...

Noise Parameters

- Sensor impedance will produce Johnson noise
 - Current and voltage modes
- Signal-to-noise (dB) = $10 \log_{10}(V_s^2/V_n^2)$
- Noise figure is ratio (in dB) of the output noise of the real amplifier to the output noise of a zero-noise amplifier (only gain) with a given resistor R_s at the input.
 - Insensitive parameter for high R_s
 - Useful for a fixed, given impedance
 - RF device at 50 Ω or a particular sensor
 - Equivalent to noise temperature (T of R_s to give noise in ideal amplifier)
- Noise adds in quadrature (if sources are uncorrelated!)

Series (current) and parallel (voltage) noise

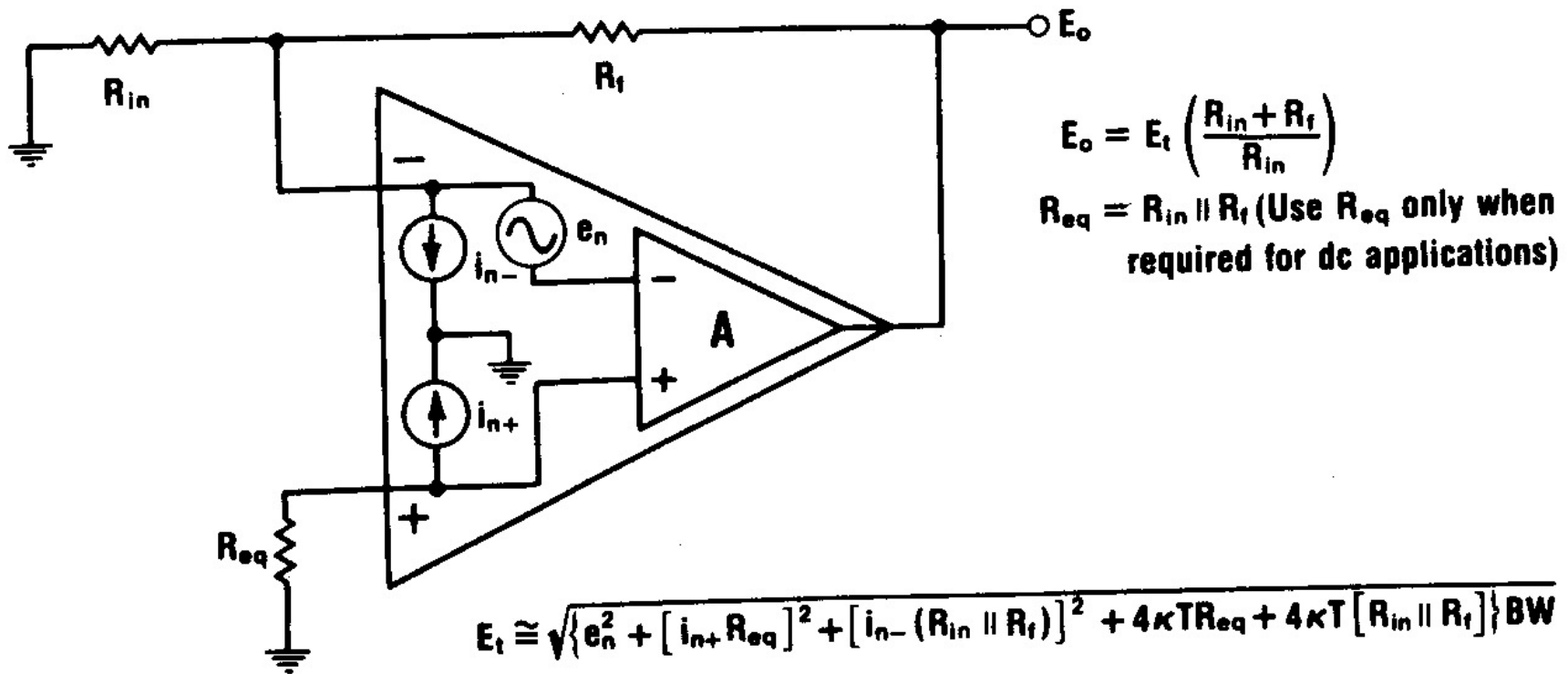

Fig. 1-20. Input current and voltage noise errors.

OpAmp noise sources come from current and voltage noise in the amplifier (referred to the input) and connected resistors

Noise in Inverting and Noninverting Amplifiers

For the noninverting amplifier (Fig. 7.56) the input noise sources become

$$i_A^2 = i_n^2$$

$$e_A^2 = e_n^2 + 4kTR_{||} + (i_n R_{||})^2$$

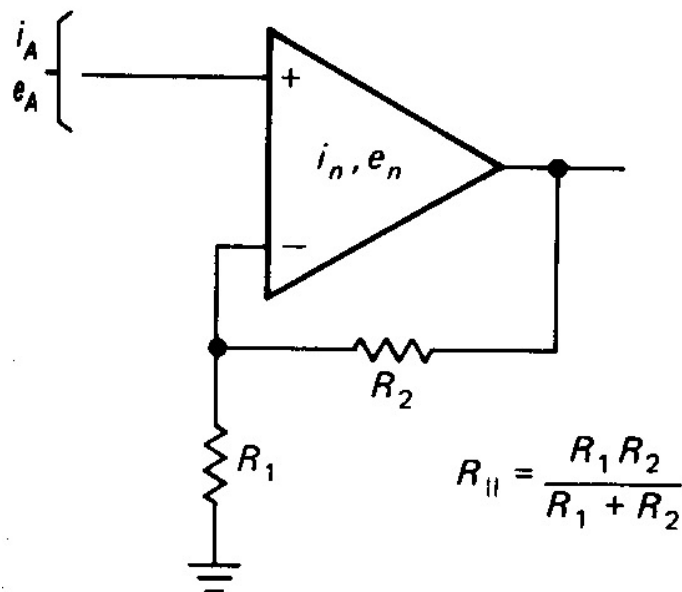

Figure 7.56

Noise gain, and the problem with capacitive loads at the inverting input
 Short answer for noise - for high impedance sources, use low i_n OpAmps
 - for low impedance sources, use low v_n OpAmps

For the inverting amplifier (Fig. 7.57) the input noise sources become

$$i_A^2 = i_n^2 + 4kT \frac{1}{R_2}$$

$$e_A^2 = e_n^2 + R_1^2 \left(i_n^2 + 4kT \frac{1}{R_2} \right)$$

$$= e_n^2 + R_1^2 i_A^2$$

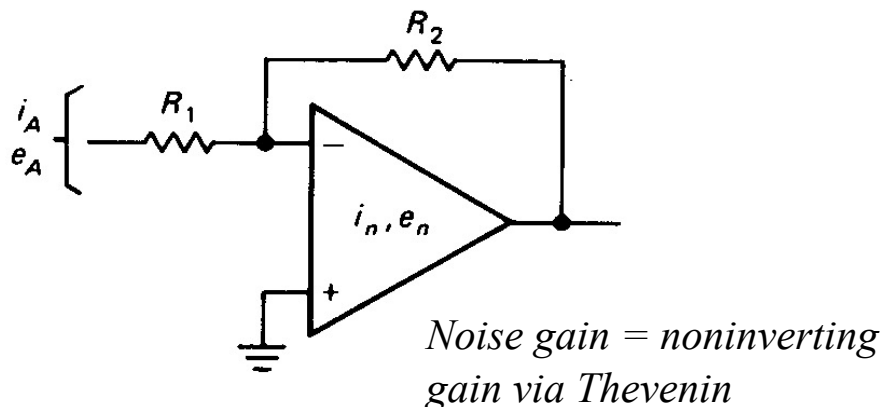

Figure 7.57

Picking a low-noise OpAmp

TABLE 7.3 Noise Parameters for Some Low-Noise Operational Amplifiers^a

Op Amp	e_n (1 kHz) (nV/ $\sqrt{\text{Hz}}$)	f_{ce} (Hz)	i_n (1 kHz) (fA/ $\sqrt{\text{Hz}}$)	f_{ci} (Hz)	E_n (pp) (0.1–10 Hz) (μV)
AD745	5	<10	6.9 ^b	120	0.38 ^b
AD797	1.2	<100	2000 ^b	—	0.05 ^b
AM427B	3	2.7	600	140	0.18
HA5127A	3.8	<10	600	<10	0.18
LMV751	7 ^b	—	10 ^b	—	—
LT1001C	11	4	120	70	0.6
LT1007	3.8	2	600	120	0.13
LT1012C	22	2.5	6	120	0.5 ^b
LT1028	1.1	3.5	1600	250	0.075
LT1113	6	120	10 ^b	—	2.4 ^b
LT1169	8	60	1	—	2.4 ^b
LT1793	8	30	1 ^b	—	2.4 ^b
MAX410	2.4	90	1200 ^b	220	0.34 ^b
NE5534	3.5	100	400 ^b	200	—
OP07	11	10	170	50	0.6
OP27A	3.8	2.7	600	140	0.18
OP77A	11	≈ 2	170	—	0.6
OP297G	17 ^b	—	20 ^{b,c}	—	0.5 ^b
OPA111AM	15	1000	0.3	—	3.3
TL051	30	100	10	—	4 ^b
TLC2201	8 ^b	50	0.6 ^b	—	0.7 ^b
TLE2027AC	3.8	3	600	—	0.13
TLE2662	60	20	1 ^b	—	1.1 ^b

^a Voltage and current values are maximal, unless noted, at 25°C, but not necessarily measured with the same voltage supply and source impedance. Frequency values are typical and some have been estimated from figures.

^b Typical values.

^c At 10 Hz.

The Non-Ideal OpAmp

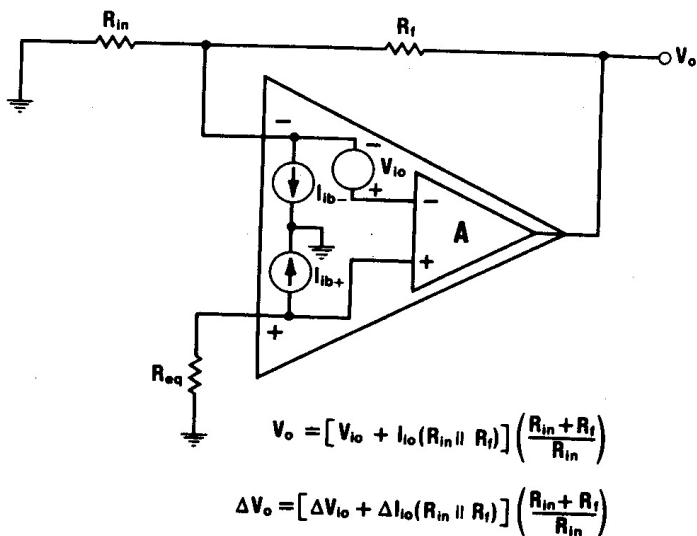
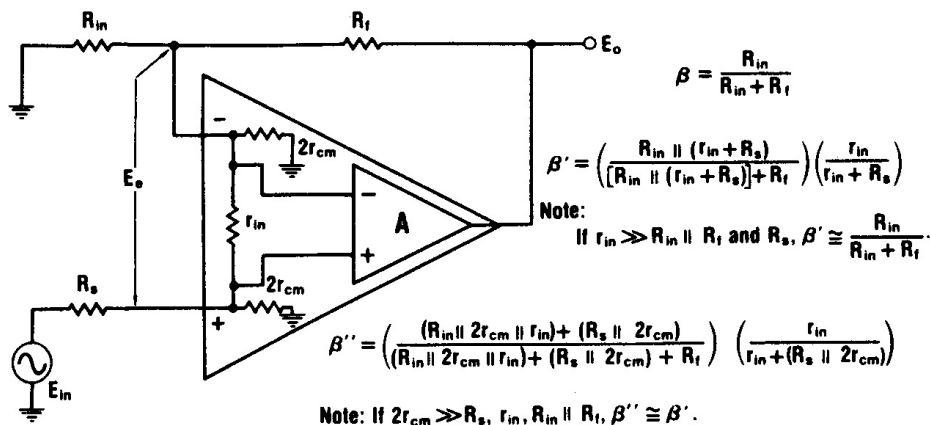

Fig. 1-18. Composite input offset-voltage and -current errors.

Offset voltage and Current

- Important for precision DC applications
- Can drift with temperature and general mood
- High impedance source
 - Use low offset current amp
(also make + and - impedance identical)
- Low impedance source
 - Use low offset voltage amp



(B) Noninverting configuration.

Finite input resistance (and CM resistance)

- Use high-Z (FET or MOSFET) amplifier where this is critical (e.g., high-Z sensor)

Fig. 1-14. Effects of finite input resistance.

The Non-Ideal OpAmp (cont.)

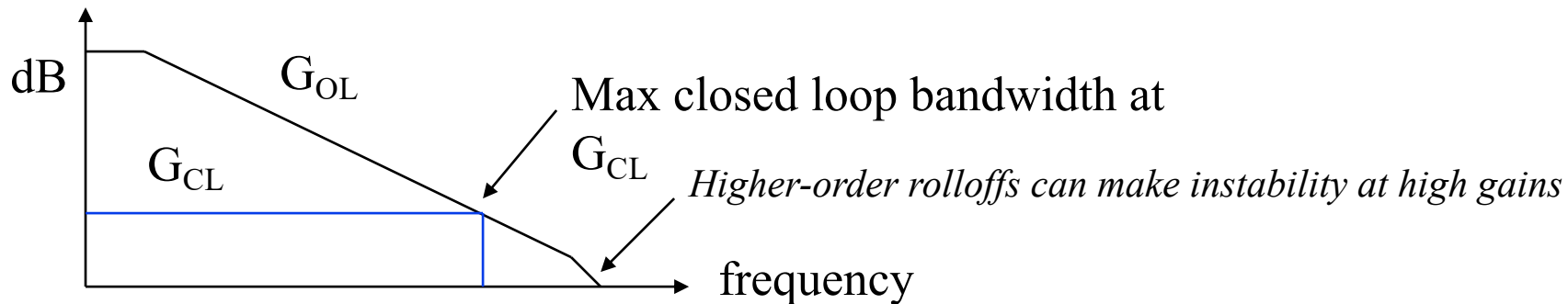

- Gain-Bandwidth limitations

- The more closed-loop gain your circuit needs, the more bandwidth you need in your OpAmp.

- Speed (slew rate)

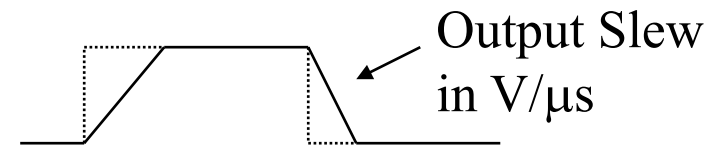

- Maximum output current (typically 20 mA, less for μpwr)

- Maximum output voltage (+ and -)

- Rail-Rail...

- Maximum input voltage

- Rail-Rail...

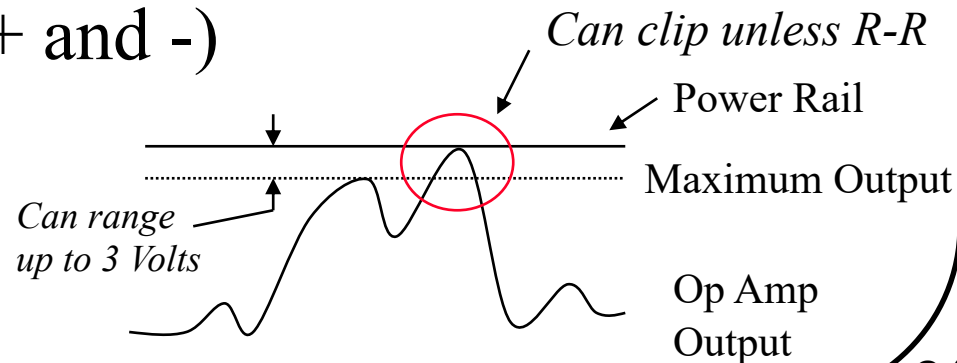

Picking an OpAmp

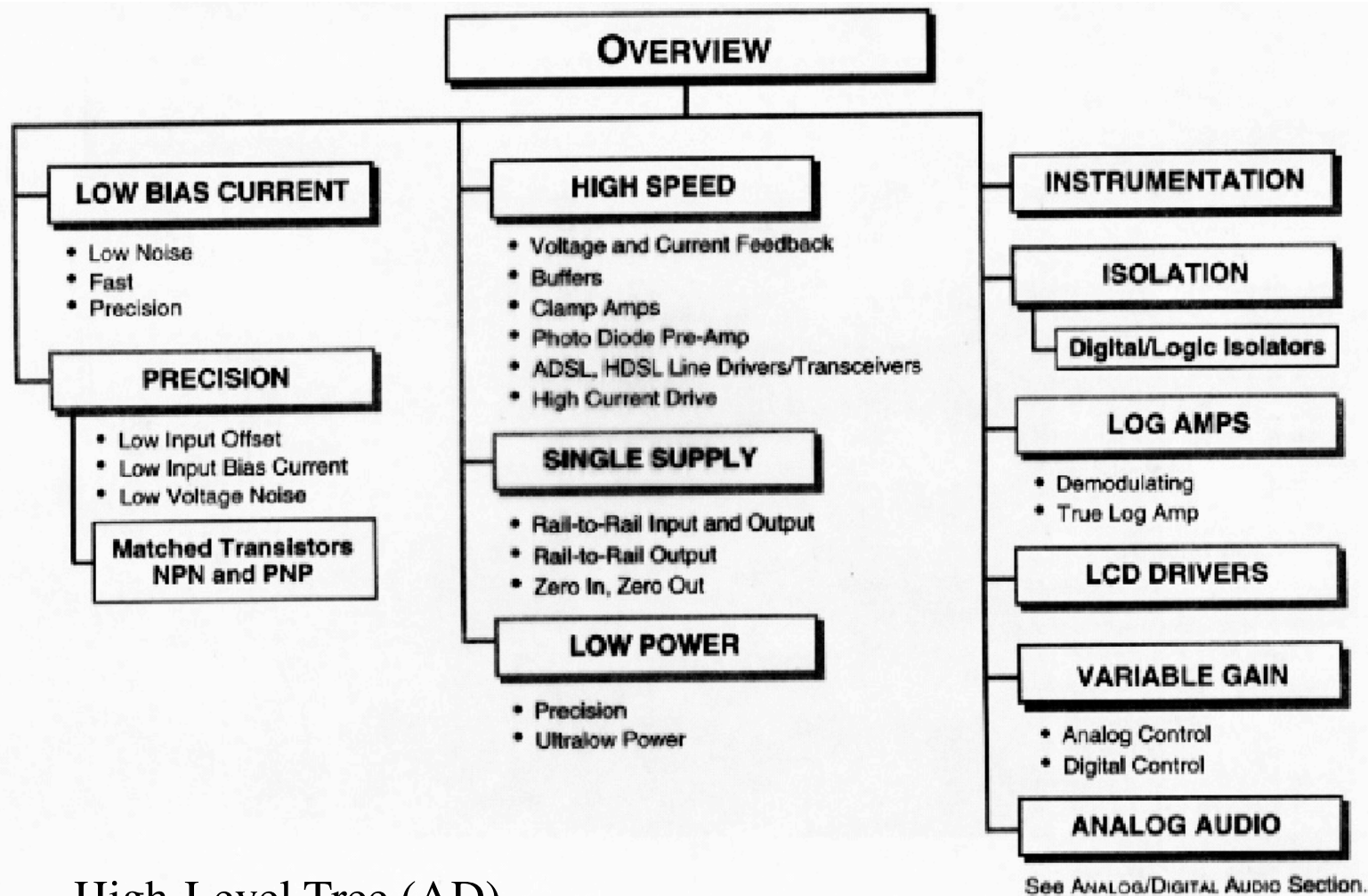

High-Level Tree (AD)

OLD

Picking a Particular OpAmp

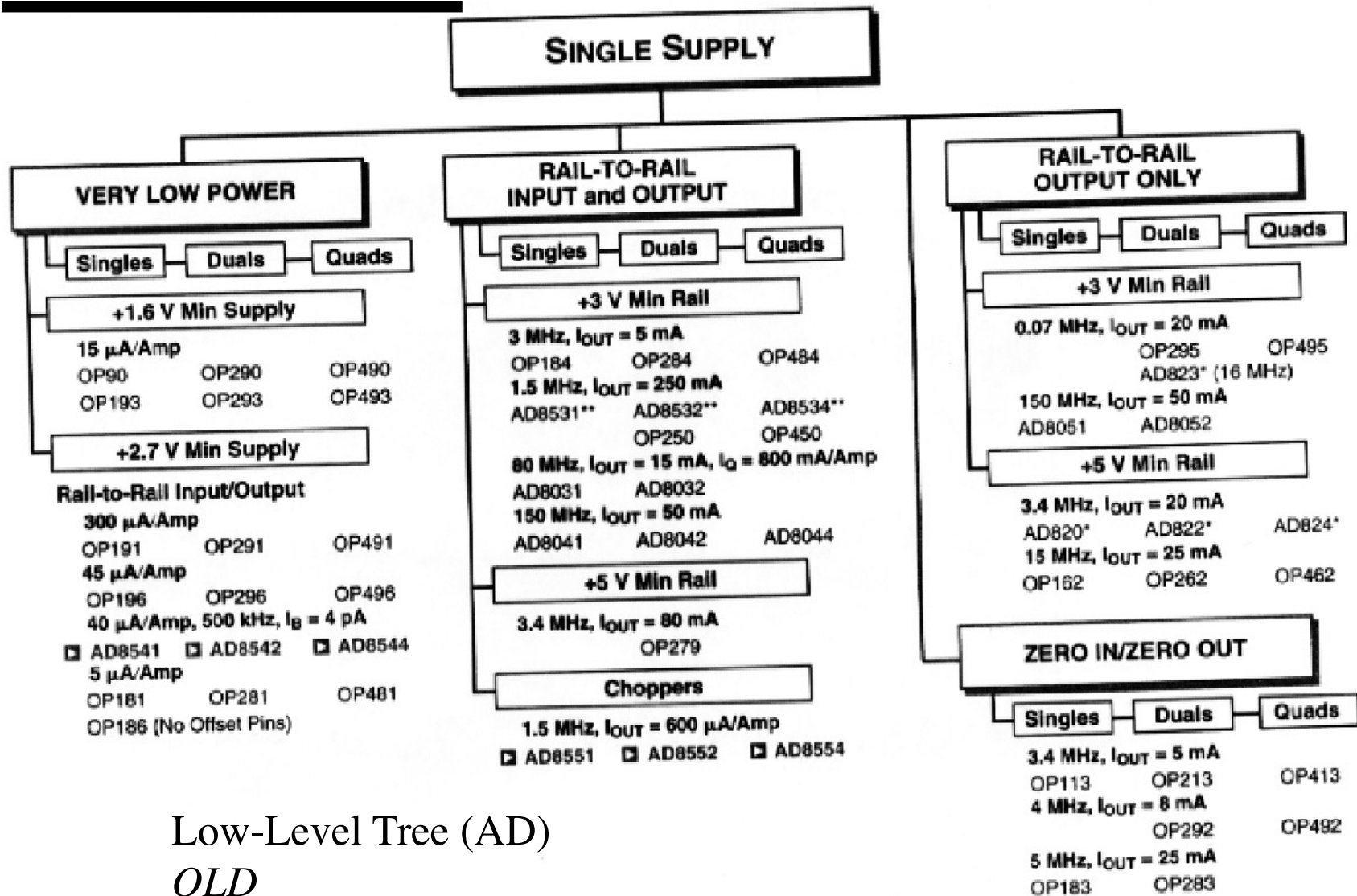

Low-Level Tree (AD)

OLD

Picking a Particular OpAmp

Parametric Search - Operational Amplifiers

Search

Include parameter:	<input type="checkbox"/>	<input type="checkbox"/>	<input type="checkbox"/>	<input type="checkbox"/>	<input type="checkbox"/>	<input type="checkbox"/>	<input type="checkbox"/>	<input type="checkbox"/>	<input type="checkbox"/>	<input type="checkbox"/>
Priority:	<input type="checkbox"/>	<input type="checkbox"/>	<input type="checkbox"/>	<input type="checkbox"/>	<input type="checkbox"/>	<input type="checkbox"/>	<input type="checkbox"/>	<input type="checkbox"/>	<input type="checkbox"/>	<input type="checkbox"/>
Part#	Small Signal Bandwidth	Slew Rate	Vos	Ib	V Noise Density	Vcc-Vee	Iq per Amplifier	Amplifiers Per Package	Package	US Price 1000-4999
Query Parameter:	<input type="text"/> MHz	=> <input type="text"/> V/ μ s	=< <input type="text"/> mV	=< <input type="text"/> nA	=< <input type="text"/> nV/rtHz	= <input type="text"/> V	=< <input type="text"/> mA	<input type="text"/>	<input type="text"/>	=< <input type="text"/> \$ US

Define a search criteria and click the 'Search' Button

Search

Add Searchable Parameters Not Currently Displayed Above

- | | | |
|--|--|--|
| <input type="checkbox"/> Total Harmonic Dist. | <input type="checkbox"/> Diff Gain | <input type="checkbox"/> Diff Phase |
| <input type="checkbox"/> Aol | <input type="checkbox"/> CMRR | <input type="checkbox"/> Input Headroom V+ |
| <input type="checkbox"/> Input Headroom V- | <input type="checkbox"/> Output Headroom V+ | <input type="checkbox"/> Output Headroom V- |
| <input type="checkbox"/> I _{out} Capability | <input type="checkbox"/> Min Stable Acl | <input type="checkbox"/> Low Frequency V Noise |
| <input type="checkbox"/> I Noise Density | <input type="checkbox"/> Low Frequency I Noise | <input type="checkbox"/> Ios |
| <input type="checkbox"/> Vos TC | <input type="checkbox"/> Rin | <input type="checkbox"/> Cin |
| <input type="checkbox"/> Capacitive Load | <input type="checkbox"/> V or I Feedback | <input type="checkbox"/> Features |
| <input type="checkbox"/> Widest Temp Range (°C) | | |

[back to top](#)

Instructions:

- **Sort:** Click on the arrows beneath the parameter on which you would like to sort.
- **Remove:** Deselect the checkbox above the appropriate parameters.
- **Add:** Select the checkboxes for those parameters that are not displayed.
- **View:** Click "Search" after removing, filtering, or adding parameters.
- **View:** Click "Reset Table" to re-initialize search

Note: Values highlighted in red are not exact matches.

Interactive Parametric Search (AD) *CURRENT*

[back to top](#)

Some of Joe's **Old** Favorites (needs updating!)

- * Ancient: 741
- * Garden variety, out to 200 Khz; not bad for audio either (LF351, TLO81/2/4, OP482/4)
- * A little better: AD711/712/713
- * Generic, single supply (pulls to ground) LM324 (quad)
- * Low Power: TLO6x, CMOS: TLC271 series (programmable power), CA3130, CA3140
- * Low Power, low V, R-R (often CMOS): LPC661IN (National), MAX494 series, OP491, TLC2274 series
- * Similar, but a bit faster: OP462 series
- * Low voltage, R-R, moderate power, good speed: MAX474/475
- * Good DC performance (low drift): LM308, OP297/497, OP27
- * Low noise, Stiff drivers (600 Ohm audio lines), standard in audio: NE5532/5534, TLE2082 series
- * Low voltage noise: AD743, AD745, AD797 (this one is touchy...)!
- * Fast OpAmps: LM318, AD817 (video; nice and stable), AD829 (low noise video)
- * Differential video amps/drivers (not really OpAmps): LM733, NE529 (stability woes... very fast and cheap)
- * Comparators (not really OpAmps either...): LM311, LM339 (quad; single supply), CA3290 (CMOS)
- * Instrumentation amplifiers (" "): Burr Brown INA series, AnalogD's AMP01 (low noise), AD623 (low V, R-R)

OPA340 3.3V supply, rail-to-rail input and output

LT1792 very low current and voltage noise

OPA129 lowest bias current (100fA), but low bandwidth

LTC1150 chopper stablized opamp, no ext. clock, pin for pin replacement for 8pin single package opamps

OpAmp Variants:

- * Norton Amplifiers (CDA's): e.g., LM3900
- * Current-Feedback Amplifiers: e.g., National Comlinear series
- * Programmable Gain Amplifiers (PGA's): e.g., AD8320, OPA675, OPA676

Mark Feldmeier on OpAmps, Comparitors, & Regulators

hey joe there really isnt a single opamp that is good for all applications but there are a few good ones for everything you will do with sensor networks you need a rail to rail as the voltages are too small

the one from the sensors class is the tlv2374 it is very similar to the tl082 except its rail to rail and has lower quiescent current but its more expensive its a good choice for starting out as it operates like an ideal opamp for a wide range of inputs and frequencies and it has extremely low bias current

the lowest quiescent current opamp out there is the tlv2402 which is less than 1uA per amplifier and there are a number of opamps in this realm but they tend to have a number of issues first off the gbw is usually less than 10khz which make them only useful for buffers or extremely slow moving signals they also have high output impedance which can sometimes be a problem if the input impedance to your a to d is too low and the bias current can be high although there are some with reasonable bias currents most are on the order of 100pA which is fine for most things except for piezos

everything else is application specific a few rules of thumb though if you want higher bandwidth you will need more power or more money you can get better speed by trading off bias current and input common mode voltage which you can usually make up for with a voltage follower and using inverting opamp configurations you either get low current noise or low voltage noise but the current noise tends to get higher on lower power opamps same with offset voltage and offset current at low current the offset voltage is usually pretty good but the offset current goes to hell so if you want to build a low power circuit use voltage mode circuits

the opa4379 is almost 1Mhz at 6uA per channel which is pretty good so you can get reasonable stuff but its four times the cost of a low cost opamp like the lpv358 which draws twice as much current for a quarter of the bandwidth at any rate you can keep going on like this forever

the other thing to consider is comparators the lowest power is 550na the tlv3402 but again low slew rate voltage range on low power stuff tends to be limited as well usually 5v rails max

switching regulators may not be the best choice for a power supply for example if you are using a lithium polymer battery which charges to 4v and discharges 90% of its power by the time it gets down to 3v you can get almost the exact same efficiency from a linear regulator as you can from a switching regulator the differences really dont make it worth the extra rf noise power supply noise or component cost and design time

but the main thing to ask when picking a switching regulator is how much output current will you need which is why they suck especially for sensor nodes when you have long periods of low current draw and a few spikes of high current draw you still need a regulator which can handle the high spikes which necessarily has a high quiescent current so for the majority of the time you are throwing away power for the few times you need it they have a number of dual mode switchers which go into shutdown when they are not sourcing much current but nothing is perfect

when you operate a switcher in its ideal condition which is usually near its max output current you can get 95% efficiency but drop a few orders of magnitude below that max current and youre talking 50% efficiency and if you try to buffer with a large power supply capacitor you effect the switch operation the frequency shifts and the output tends to come in packets

i dont have any specific reccomendations here again its very application specific

i know mat uses the bq series battery charger and voltage regulator in one chips from ti they are handy because they do a lot in a small form factor.

Ari Benbasat on OpAmps

Here is the low-power op amp I spec'ed out for my thesis and/or future Stack work:

"...the Maxim MAX9911 is recommended. It is available in a single SC70 package (5mm²) with shutdown, and has a turn on time of 30 us. Typical current draw is 4 uA with a shutdown draw of 1 nA. The gain bandwidth product of 200 kHz is acceptable for most uses."

Voltage Regulators

- Series Regulators are simple often 3-terminal devices (in-gnd-out) that step an input voltage down to a lower (stable) reference voltage
 - Waste power dissipated = $(\Delta V)(I)$
 - Keep within device limits to avoid overheating
 - Maximum ΔV ranges from approx. 100 mV to 3 V, depending on device, currents range from 100 mA to many Amperes
- Switched Capacitor Regulators provide limited current w. minimal components, and can boost voltage.
- Inductive switching regulators require external inductor and possibly other components, but can raise (boost) or lower (buck) voltage at very high (over 90%) efficiency. Some regulators can switch from boost to buck to keep running as the battery dies
 - These regulators transform impedance
- Many regulators of all types often include a “battery low” output

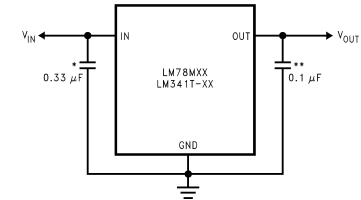

Students Advice on Regulators

Mat Laibowitz

For power supply circuitry, Texas Instruments is the best. Well, at least they have the best literature making it easy to find a solution. The TI Power Management Selection Guide at <http://www.ti.com/litv/pdf/slv145g> is indispensable and has all their chips by application with example circuits. For portable devices, they have the battery specific version of the selection guide: <http://www.ti.com/litv/pdf/slym061a6>. And this site has up-to-date info for portable power: <http://focus.ti.com/analog/docs/gencontent.tsp?familyId=64&genContentId=2172>

Mark Feldmeier

switching regulators may not be the best choice for a power supply for example if you are using a lithium polymer battery which charges to 4v and discharges 90% of its power by the time it gets down to 3v you can get almost the exact same efficiency from a linear regulator as you can from a switching regulator the differences really don't make it worth the extra rf noise power supply noise or component cost and design time

but the main thing to ask when picking a switching regulator is how much output current will you need which is why they suck especially for sensor nodes when you have long periods of low current draw and a few spikes of high current draw you still need a regulator which can handle the high spikes which necessarily has a high quiescent current so for the majority of the time you are throwing away power for the few times you need it they have a number of dual mode switchers which go into shutdown when they are not sourcing much current but nothing is perfect

when you operate a switcher in its ideal condition which is usually near its max output current you can get 95% efficiency but drop a few orders of magnitude below that max current and you're talking 50% efficiency and if you try to buffer with a large power supply capacitor you affect the switch operation the frequency shifts and the output tends to come in packets

i don't have any specific recommendations here again it's very application specific

i know mat uses the bq series battery charger and voltage regulator in one chips from ti they are handy because they do a lot in a small form factor.

Check also products by Maxim, Linear Technologies, etc.

Other Sources of Noise

- Pickup!!!
 - Capacitive coupling (high-Z sensors)
 - Shield, use differential pair cable and perhaps differential front end
 - Inductive coupling (low-Z sensors)
 - Use differential pair, shield w. high-permiability material (iron or μ -metal), reorient components (vector coupling)
 - Shielded cable
 - Shielded pair
 - Ground shield at signal source

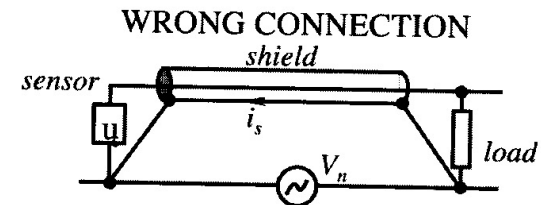
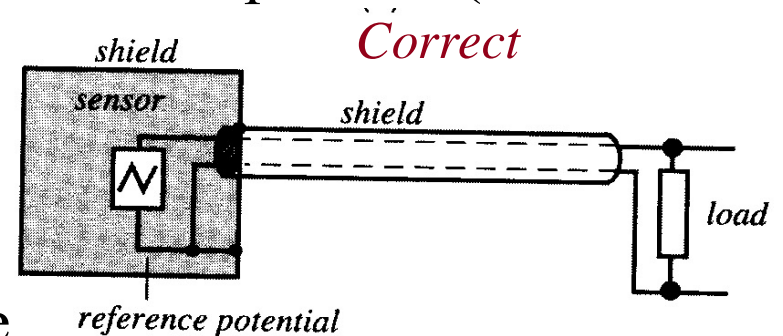

Black Magic!

Driven Shields

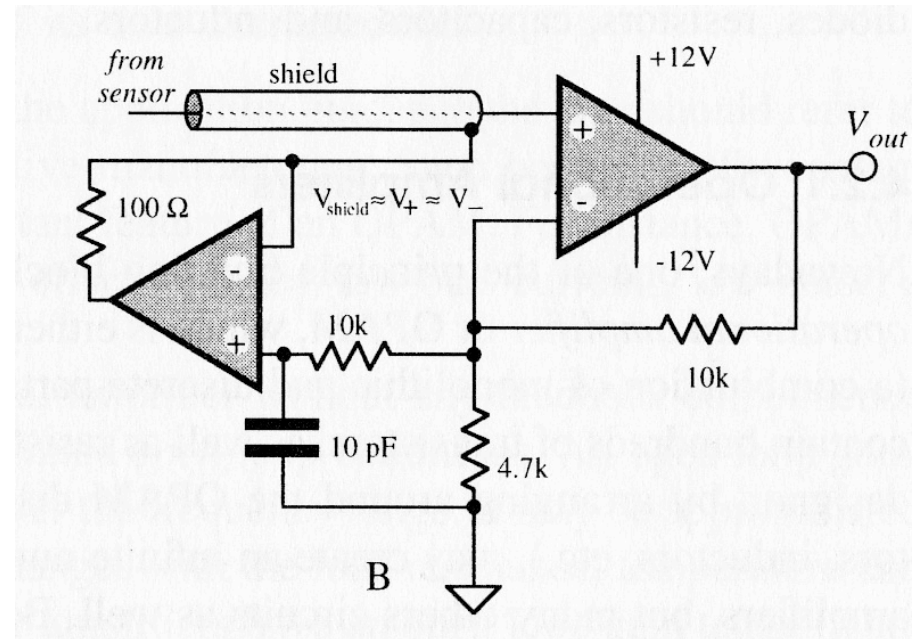
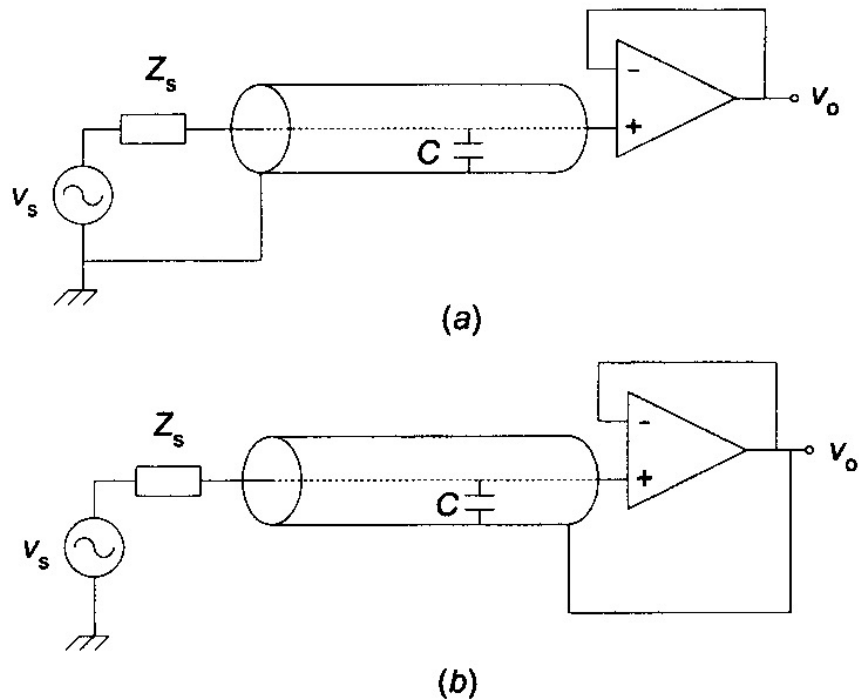

- Servoes out capacitance on shield
 - Use where loading of cable is problematic
 - Capacitive Sensors

Guard Electrodes

- On-Board Driven Shields to prevent crosstalk and coupling
- Guards should be driven by a low-impedance source close to the voltage on the electrodes to be guarded
 - E.g., a driven shield, or a ground in an inverting op-amp configuration

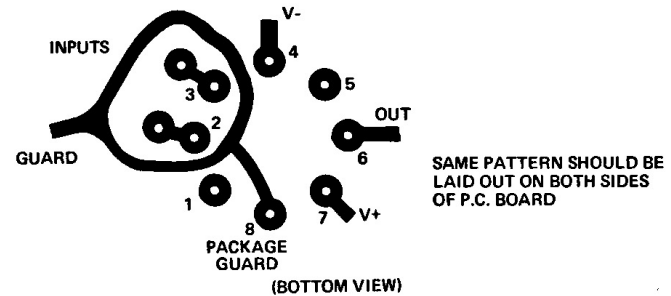

b. Board layout for guarding inputs of AD515 with guarded TO-99 package

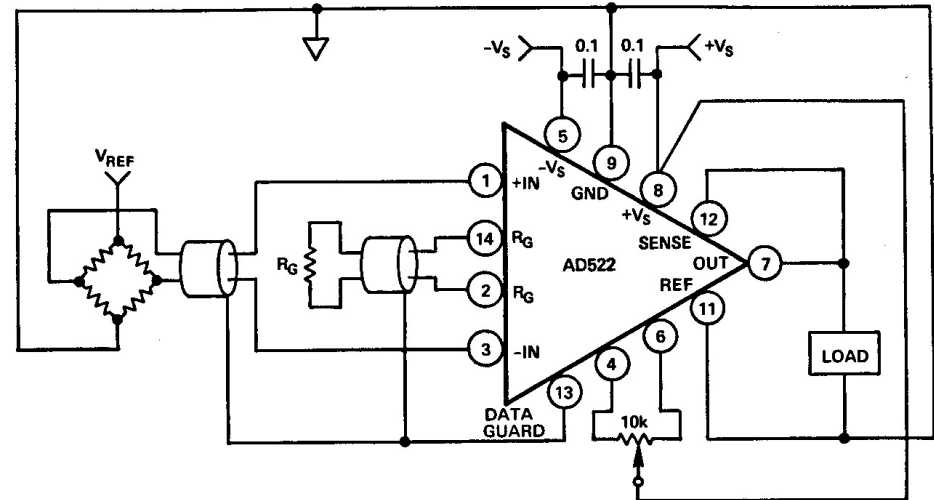

c. Use of the AD522 instrumentation amplifier's guard terminal to guard both the input connections and connections to a remote gain-setting resistor

Figure 3-6. Guarding

Other Types of Pickup

- Lack of **Bypass Capacitors**
 - Put them (.1 uF) at the power terminals of every component
 - Use a groundplane
- Microphonics
 - Jiggling things...
 - Lock it all down
 - RF detection with nonlinear junctions
 - Shield, shield, shield...
 - Ionizing radiation
 - Lead, etc.

Ground Loops

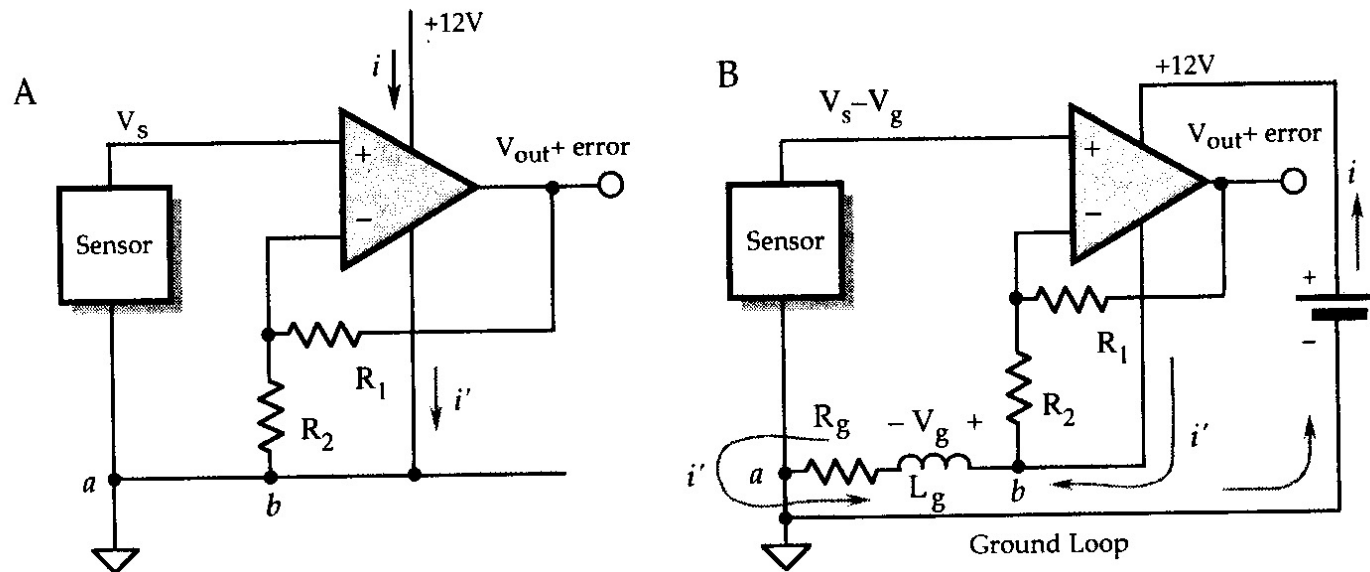

FIGURE 4.61. Wrong connection of a ground terminal to a circuit (A); path of a supply current through the ground conductors (B).

- Ground loops are caused by running (or daisy-chaining) the power supply past too many loads
 - Resistive and inductive components of the “wire” cause voltages to be dropped as current is pulled
 - Wire everything directly to the power supply!

More Ground Loops

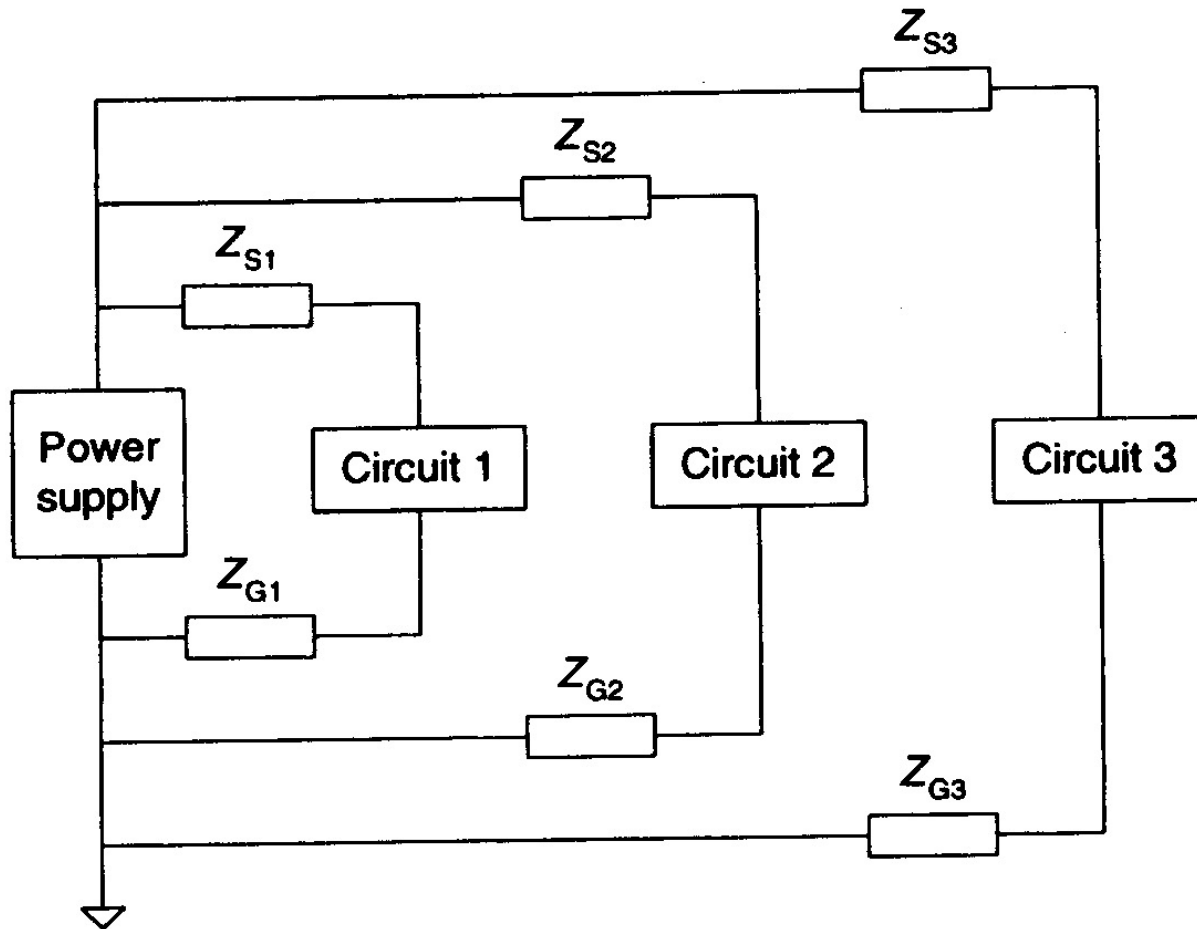
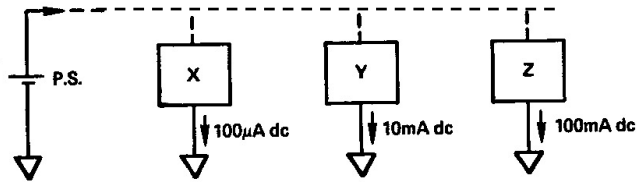

FIGURE 10.12 Power distribution with separated supply lines for each circuit to reduce interference resulting from a common impedance.

The Right Way...

Successive Approaches



a. Basic circuit

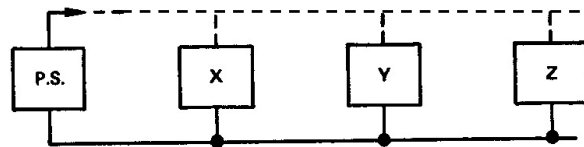

b. Circuit as drawn

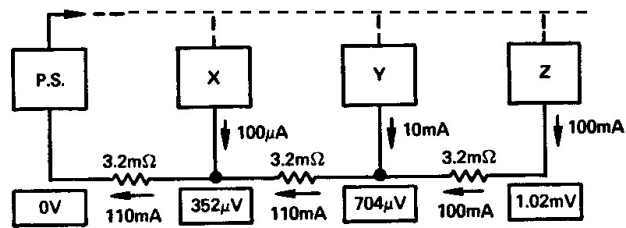

c. Circuit wired with 6" lengths of #18 wire. Voltages at each "ground" point are shown.

Bad

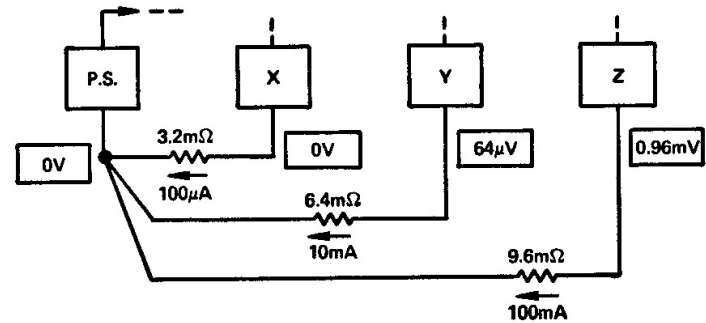

d. Circuit wired to single-point ground

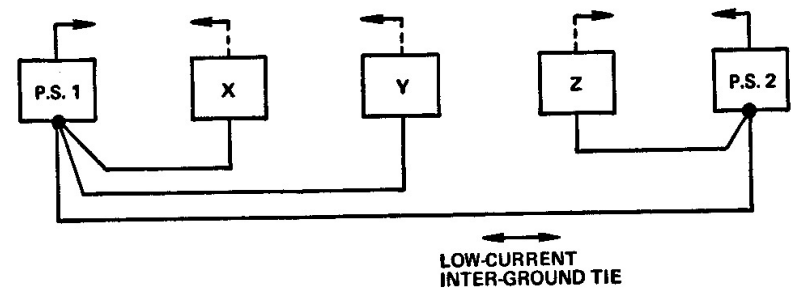

e. Separate supply for Z

Good

Mixed Signal Systems

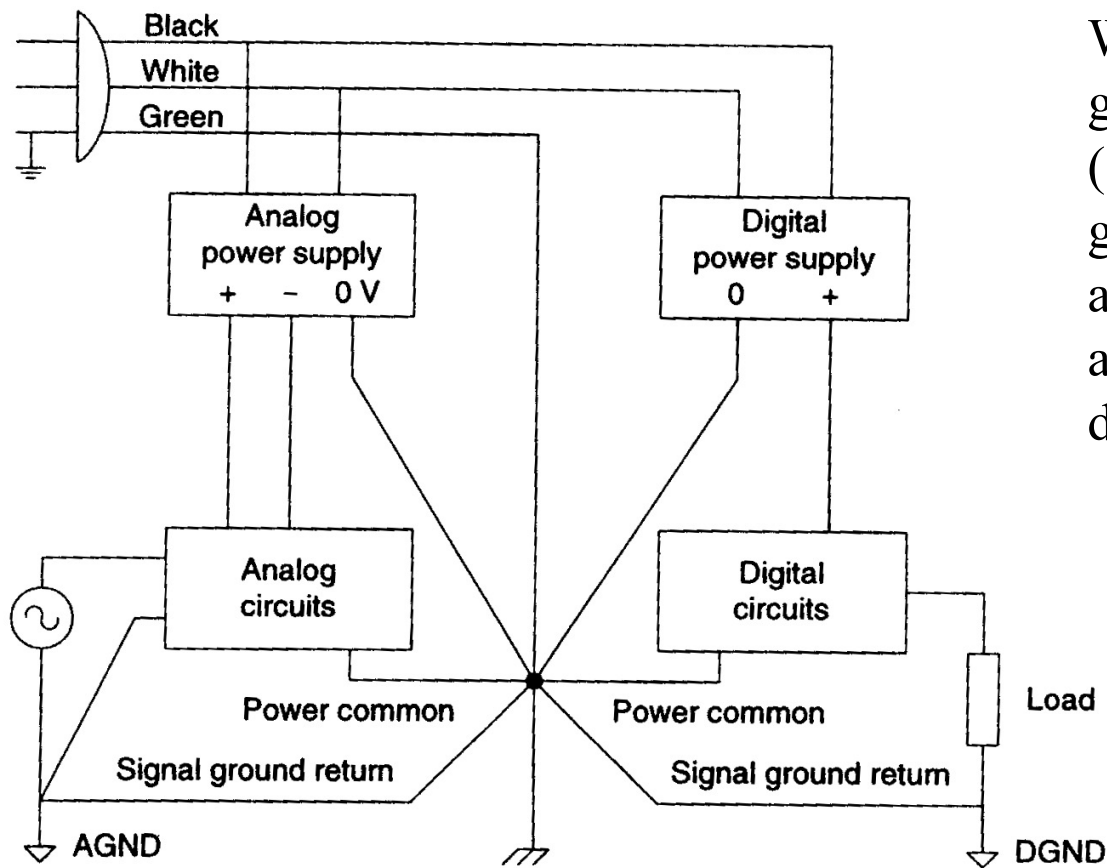

FIGURE 10.13 Power supply distribution and grounding in a system with analog and digital circuits.

Where possible, pour ground and power planes (separate digital & analog ground except at junction), avoid running sensitive analog signals past noisy digital lines.

- Worship the Star...

Jason adds more here!

Mixed-Signal Cards

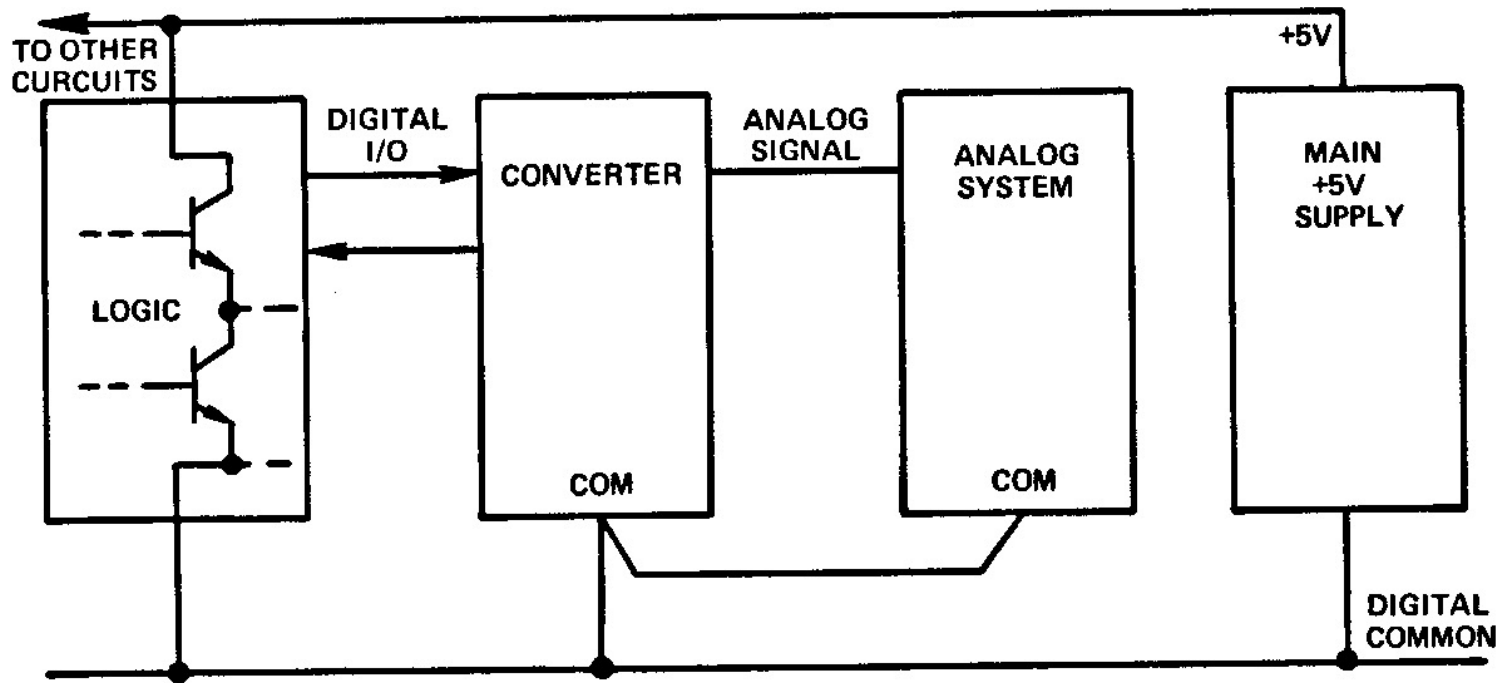
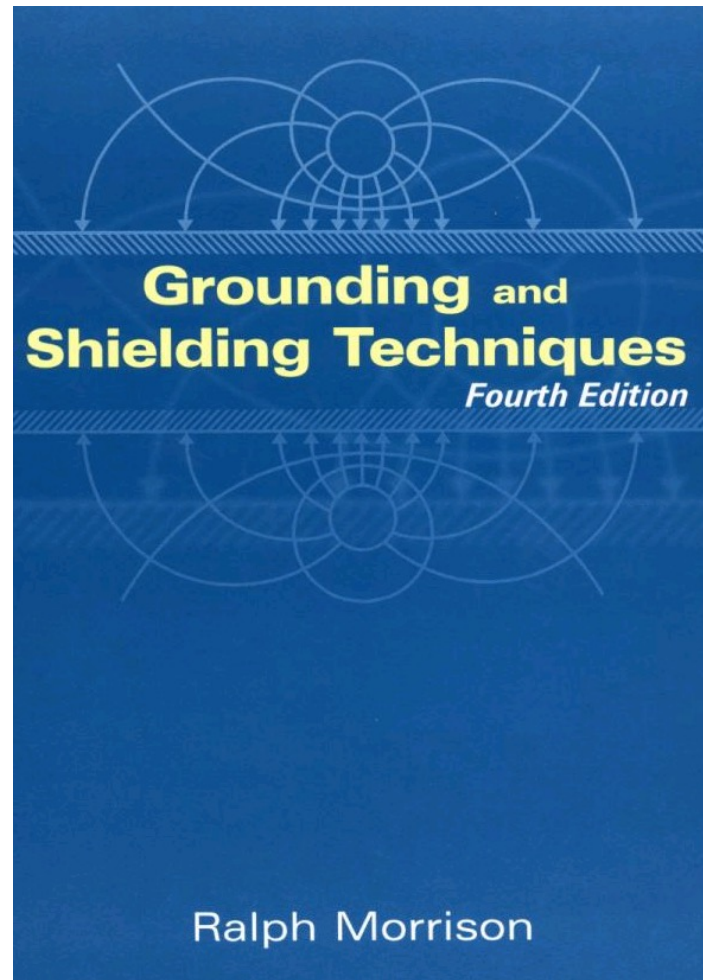
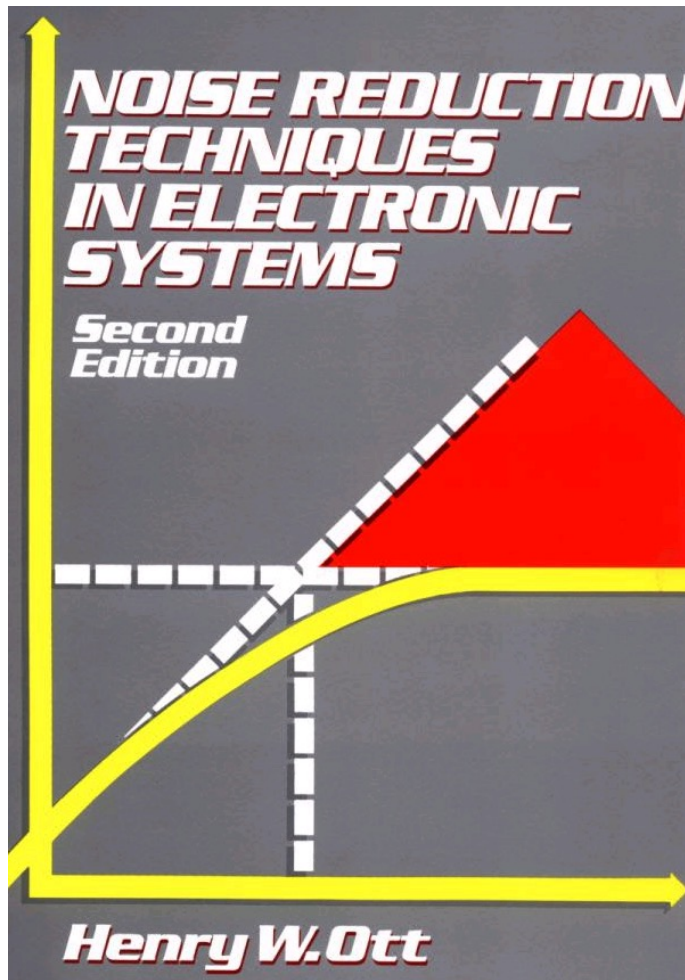

Figure 3-2. This connection minimizes common impedance between analog and digital (including converter digital currents)

- The ADC lives between digital and analog

Many books on the subject...



... But it's often a black art!

Very Basic Digital Noise Reduction

- Remove outliers
- Average the signals
 - Summing N signals results in a resolution improvement of a factor \sqrt{N}
 - Provided that measurements are uncorrelated and exhibit Gaussian statistics
 - Must not be quantization limited
 - I.e., you **need** some noise to start with!
 - Note that this is **not** usually true for pickup, which is from a correlated source!
 - Pickup noise can add in phase
 - Linearly!!!
 - L3 BGO story...

L3 BGO Electromagnetic Calorimeter

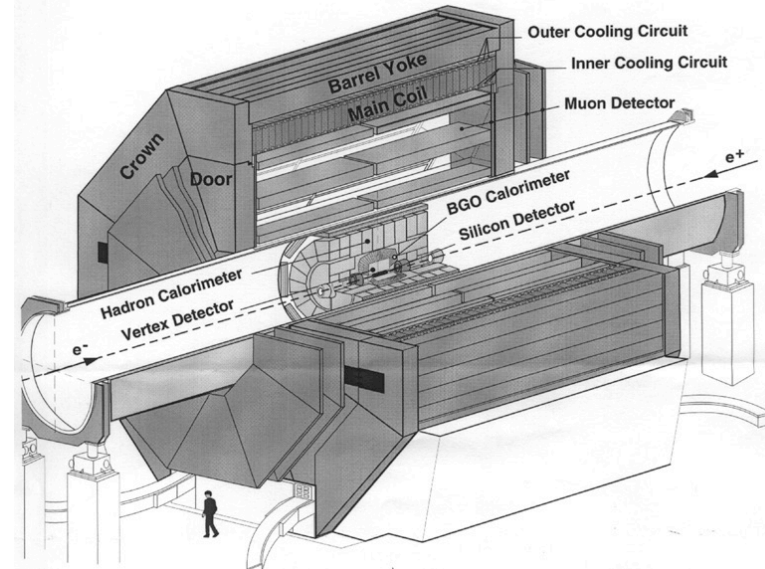
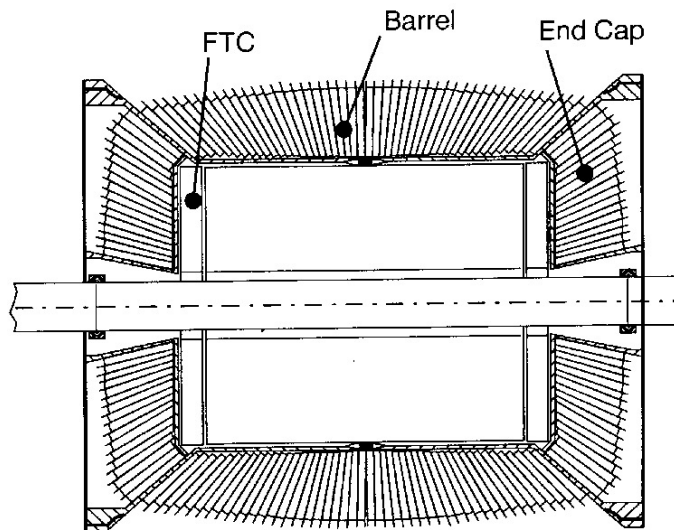
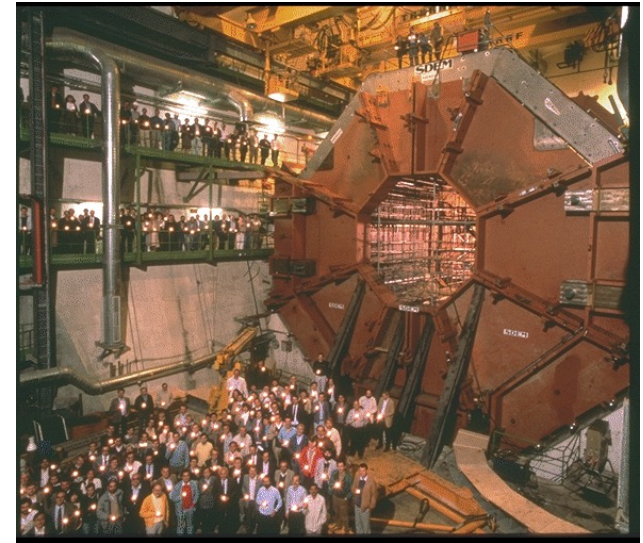
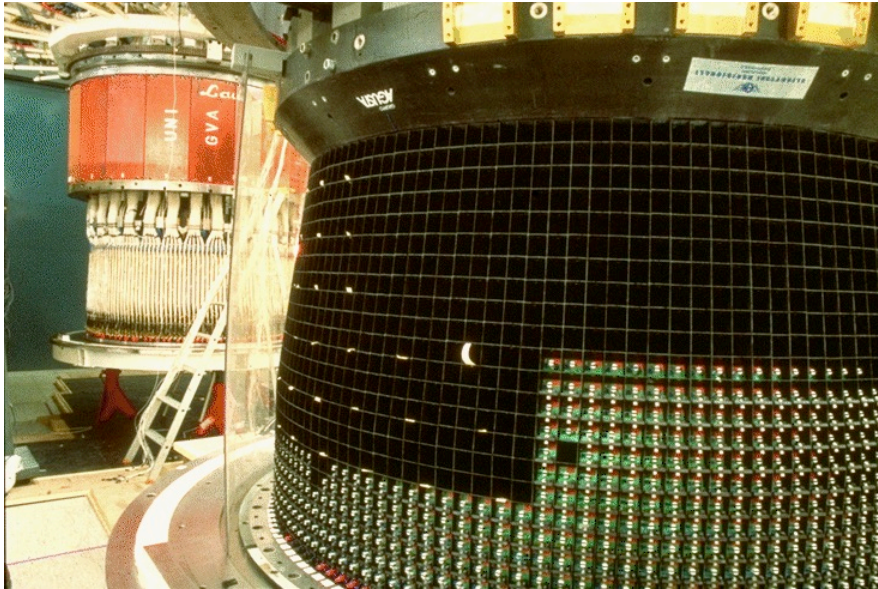

Isolation and Protection

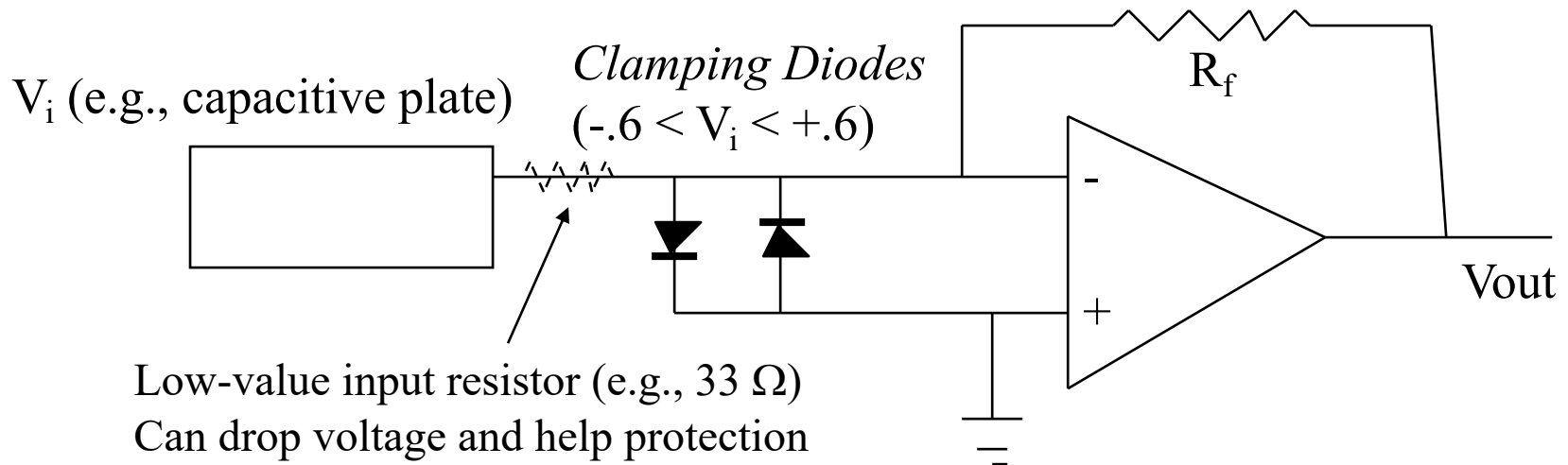

- Diode Protection for inputs
 - e.g., from static electricity (ESD), actuator voltage, etc.
- Isolation Amplifiers
 - Inductive
 - Optical
 - Capacitive

Inductive(?) Isolation Amplifier



Precision, Wide Bandwidth 3-Port Isolation Amplifier

AD210*

FEATURES

High CMV Isolation: 2500 V rms Continuous
±3500 V Peak Continuous

Small Size: 1.00" × 2.10" × 0.350"

Three-Port Isolation: Input, Output, and Power

Low Nonlinearity: ±0.012% max

Wide Bandwidth: 20 kHz Full-Power (-3 dB)

Low Gain Drift: ±25 ppm/°C max

High CMR: 120 dB (G = 100 V/V)

Isolated Power: ±15 V @ ±5 mA

Uncommitted Input Amplifier

APPLICATIONS

Multichannel Data Acquisition

High Voltage Instrumentation Amplifier

Current Shunt Measurements

Process Signal Isolation

FUNCTIONAL BLOCK DIAGRAM

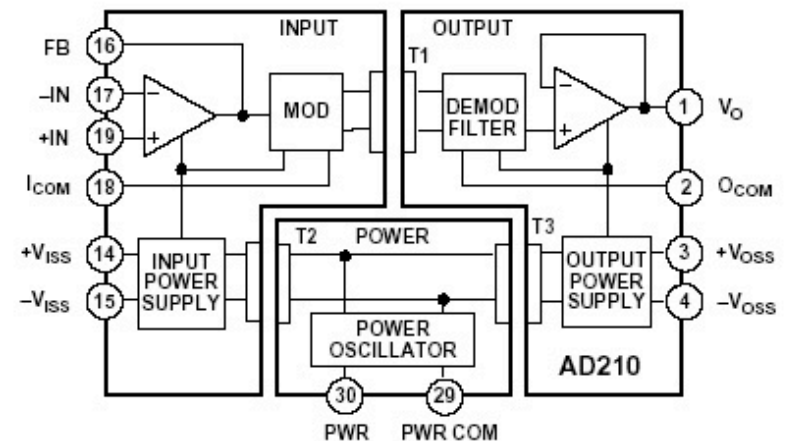

Other Isolation Amplifiers

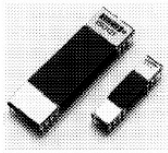

ISO120
ISO121

Precision Low Cost ISOLATION AMPLIFIER

FEATURES

- 100% TESTED FOR PARTIAL DISCHARGE
- ISO120: Rated 1500Vrms
- ISO121: Rated 3500Vrms
- HIGH IMR: 115dB at 60Hz
- USER CONTROL OF CARRIER FREQUENCY
- LOW NONLINEARITY: $\pm 0.01\%$ max
- BIPOLAR OPERATION: $V_o = \pm 10V$
- 0.3"-WIDE 24-PIN HERMETIC DIP, ISO120
- SYNCHRONIZATION CAPABILITY
- WIDE TEMP RANGE: $-55^\circ C$ to $+125^\circ C$ (ISO120)

APPLICATIONS

- INDUSTRIAL PROCESS CONTROL: Transducer Isolator for Thermocouples, RTDs, Pressure Bridges, and Flow Meters, 4mA to 20mA Loop Isolation
- GROUND LOOP ELIMINATION
- MOTOR AND SCR CONTROL
- POWER MONITORING
- ANALYTICAL MEASUREMENTS
- BIOMEDICAL MEASUREMENTS
- DATA ACQUISITION
- TEST EQUIPMENT

DESCRIPTION

The ISO120 and ISO121 are precision isolation amplifiers incorporating a novel duty cycle modulation-demodulation technique. The signal is transmitted digitally across a 2pF differential capacitive barrier. With digital modulation the barrier characteristics do not affect signal integrity, which results in excellent reliability and good high frequency transient immunity across the barrier. Both the amplifier and barrier capacitors are housed in a hermetic DIP. The ISO120 and ISO121 differ only in package size and isolation voltage rating.

These amplifiers are easy to use. No external components are required for 60kHz bandwidth. With the addition of two external capacitors, precision specifications of 0.01% max nonlinearity and $150\mu V/^\circ C$ max V_{os} drift are guaranteed with 6kHz bandwidth. A power supply range of $\pm 4.5V$ to $\pm 18V$ and low quiescent current make these amplifiers ideal for a wide range of applications.

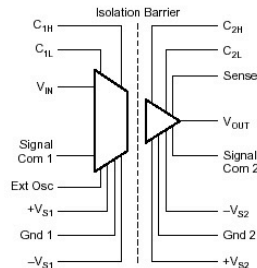

Capacitive coupling
Optical analog isolation amps...
- Homebuilt around LDR's
- Feedback linearization..

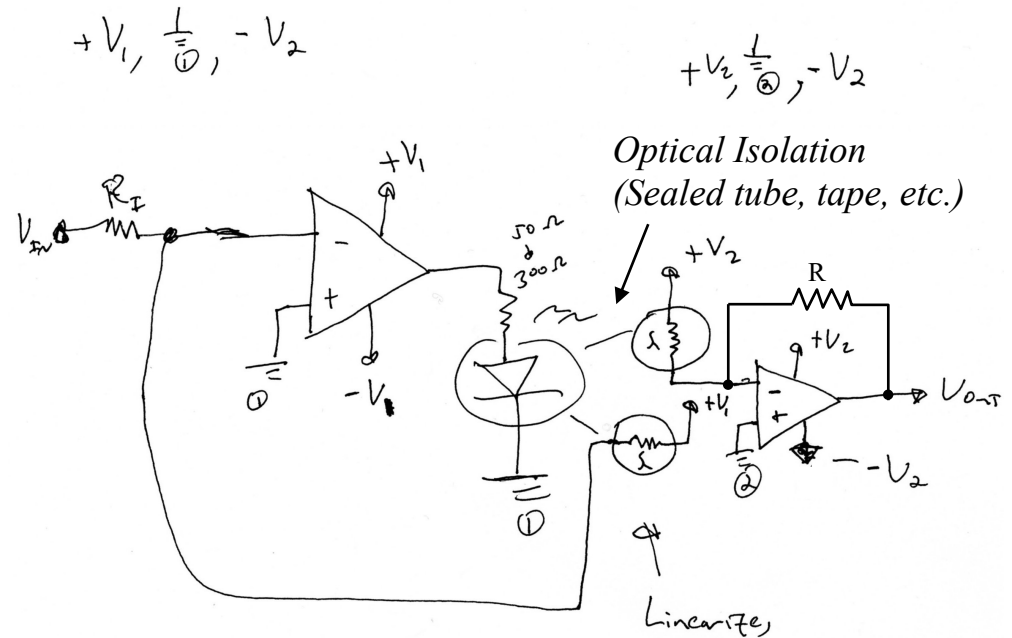

Uses LDR's - can use photodiodes too.

Instead of dual receiver coupling, can drive 2 identical LEDs and couple each independently